

Indexing and Hashing

CS460 Databases for Data Scientists



Previously on Database Technology

- We can find information in databases
 - e.g., employees by name:
`SELECT * FROM employee WHERE name = 'Brandt'`
 - e.g., employees within a range of salary
`SELECT * FROM employee WHERE salary > 50000`



A Small Experiment

- Finding data in a “physical database”
- I want two volunteers to find
 - ...the phone number of Ms. Jeske in Aalen (Das Örtliche)
 - ...the person with phone number 529743 in Aalen (Das Telefonbuch)

Finding Information in Databases

- How does that work, actually?
 - `SELECT * FROM employee WHERE name = 'Brandt'`
- Naive approach (called *linear search*):
 - Go through the table from top to bottom
 - Find and return all employees with name 'Brandt'
- Complexity: $O(N)$
 - Note that even if we find a "Brandt" earlier, we need to search further, since there might be more people named "Brandt"
 - and the query is expected to return them all

ID	name	dept_name	salary
22222	Einstein	Physics	95000
12121	Wu	Finance	90000
32343	El Said	History	60000
45565	Katz	Comp. Sci.	75000
98345	Kim	Elec. Eng.	80000
76766	Crick	Biology	72000
10101	Srinivasan	Comp. Sci.	65000
58583	Califieri	History	62000
83821	Brandt	Comp. Sci.	92000
15151	Mozart	Music	40000
33456	Gold	Physics	87000
76543	Singh	Finance	80000

Finding Information in Databases

- How does that work, actually?
 - `SELECT * FROM employee WHERE name = 'Brandt'`
- Better approach
 - Let's assume we have sorted the table by name
- We can now apply *binary search*
 - Get element in the middle of the table
 - If the searched element is “smaller”
 - Search the upper half table
 - Else
 - Search the lower half table



ID	name	dept_name	salary
83821	Brandt	Comp. Sci.	92000
58583	Califieri	History	62000
76766	Crick	Biology	72000
22222	Einstein	Physics	95000
32343	El Said	History	60000
33456	Gold	Physics	87000
45565	Katz	Comp. Sci.	75000
98345	Kim	Elec. Eng.	80000
15151	Mozart	Music	40000
76543	Singh	Finance	80000
10101	Srinivasan	Comp. Sci.	65000
76543	Wu	Finance	90000

Finding Information in Databases

- Binary search
 - Works in $O(\log_2 N)$
- However
 - Sorting the table requires $O(N * \log_2 N)$
 - i.e., complexity for search would also be $O(N * \log_2 N)$ remember:
 $O(N * \log_2 N + \log_2 N) = N * \log_2 N$
- This pays off only if we sort once and query often
 - Total complexity for S binary searches:
 $O(S * \log_2 N) + O(N * \log_2 N)$
 - Total complexity for N linear searches: $O(S * N)$
 - i.e., binary search is better if $S > \log_2 N$
 - for 1,000,000 entries: more than 20 searches

ID	name	dept_name	salary
83821	Brandt	Comp. Sci.	92000
58583	Califieri	History	62000
76766	Crick	Biology	72000
22222	Einstein	Physics	95000
32343	El Said	History	60000
33456	Gold	Physics	87000
45565	Katz	Comp. Sci.	75000
98345	Kim	Elec. Eng.	80000
15151	Mozart	Music	40000
76543	Singh	Finance	80000
10101	Srinivasan	Comp. Sci.	65000
76543	Wu	Finance	90000

Finding Information in Databases

- Binary search
 - Sort & search pays off after $\log_2 N$ searches
- But wait... what if our next query is
`SELECT * FROM employee WHERE salary > 50000`
- Now, the table is sorted by name,
not salary
 - If we re-sort before every query,
it gets even worse than by linear search!

ID	name	dept_name	salary
83821	Brandt	Comp. Sci.	92000
58583	Califieri	History	62000
76766	Crick	Biology	72000
22222	Einstein	Physics	95000
32343	El Said	History	60000
33456	Gold	Physics	87000
45565	Katz	Comp. Sci.	75000
98345	Kim	Elec. Eng.	80000
15151	Mozart	Music	40000
76543	Singh	Finance	80000
10101	Srinivasan	Comp. Sci.	65000
76543	Wu	Finance	90000

Finding Information in Databases

- Naive solution
 - Provide copies of each table sorted by each attribute we may need

- Really?!
 - We've always tried to *reduce* redundancy
 - Not to *increase* it...

- More sophisticated solution:
 - Index structures

ID	name	dept_name	salary		
83821	Brandt	Comp. Sci.	92000	0	0
58583	Califieri	History	62000	0	0
76766	Crick	Biology	72000	0	0
22222	Einstein	Physics	95000	0	0
32343	El Said	History	60000	0	0
33456	Gold	Physics	87000	0	0
45565	Katz	Comp. Sci.	75000	0	0
98345	Kim	Elec. Eng.	80000	0	0
15151	Mozart	Music	40000	0	0
76543	Singh	Finance	80000	0	0
10101	Srinivasan	Comp. Sci.	65000	0	
76543	Wu	Finance	90000		

Index Files

- Index files
 - Provide a compromise between re-sorting
 - and copying the table

- Idea
 - Provide a sorted file of a single attribute only
 - Allows linear search
 - Index file contains pointers to actual file
 - Which may or may not be sorted

Index Files

- Basic idea
 - Search in index is $O(\log_2 N)$
 - Following link is $O(1)$
 - Each index can remain sorted
 - Create an index for each attribute which you may use in a query
- Trade-off
 - Faster queries
 - Slower inserts/updates/deletions
 - *Some* redundancy
 - But this is handled by the DBMS!
 - i.e., mainly a storage capacity problem, not so much a consistency problem

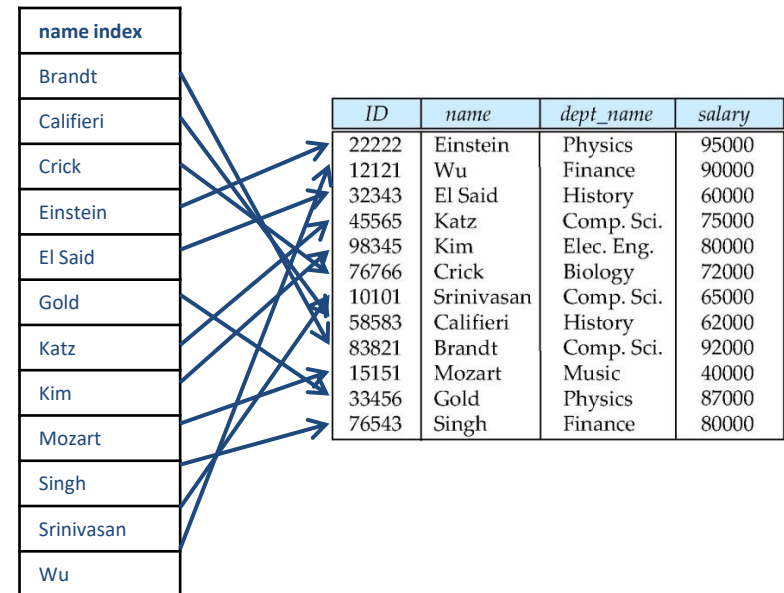

Index Files and Joins

- Understanding the need for an index file
 - Analyzing possible queries
- First use case: search attributes
 - quite straight forward
- Second use case: joins
- Suppose we want to query for the building of an instructor by name
 - *name* on *instructor* is straight forward for an index candidate
 - Query processing:
 - find instructor by name
 - read *dept_name*
 - look up *dept_name* in *department*

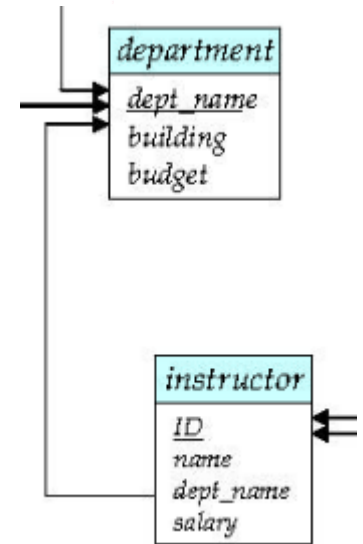

hence, we need an index
on *dept_name*
in *department*!

Index Files – Basic Concepts

- Indexing mechanisms used to speed up access to desired data
 - e.g., searching by a specific attribute
 - but also: joins!
- Search Key - attribute to set of attributes used to look up records in a file
 - An index file consists of records (called index entries) of the form



- Two basic kinds of indices:
 - Ordered indices: search keys are stored in sorted order
 - Hash indices: search keys are distributed uniformly across “buckets” using a “hash function”

Metrics for Evaluating Index Structures

- Access types supported efficiently
 - records with a specified value in the attribute
 - or records with an attribute value falling in a specified *range* of values
- Access time
- Insertion time
 - Note: index needs to be updated as well
- Deletion time
 - Note: may require deletion from index
- Storage space overhead



Ordered Indices

- In an ordered index, index entries are stored *sorted* on the search key value
 - allows $O(\log_2 N)$ search
- Primary index: in a sequentially ordered file, the index whose search key specifies the sequential order of the file
 - Also called *clustering index*
 - Search key: usually (but not necessarily) the primary key
- Secondary index: an index whose search key specifies an order different from the sequential order of the file
 - Also called *non-clustering index*

Dense vs. Sparse Index Files

- Dense index: index record appears for every search-key value
 - e.g., index on *ID* attribute of *instructor* relation

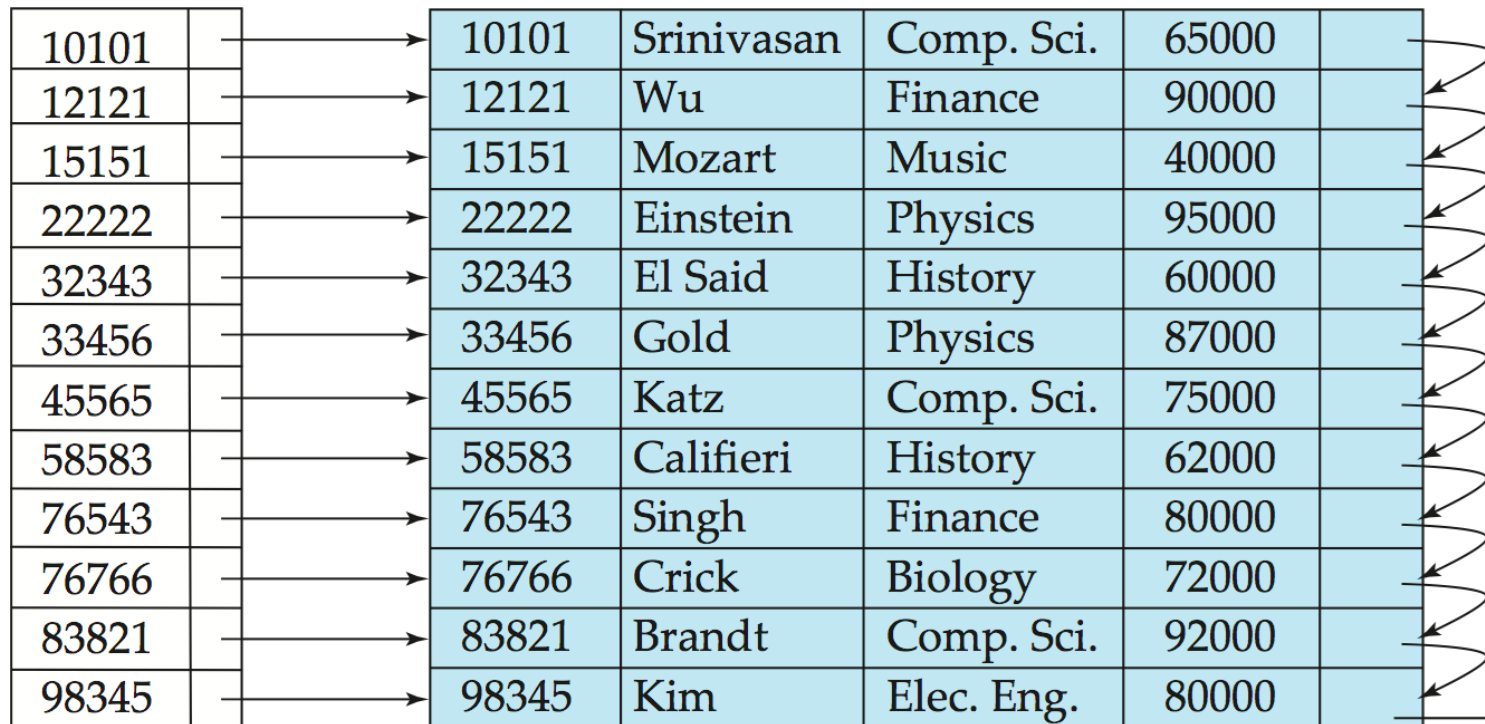

Dense vs. Sparse Index Files

- Dense index: index record appears for every search-key value
 - e.g., index on *department* attribute of *instructor* relation

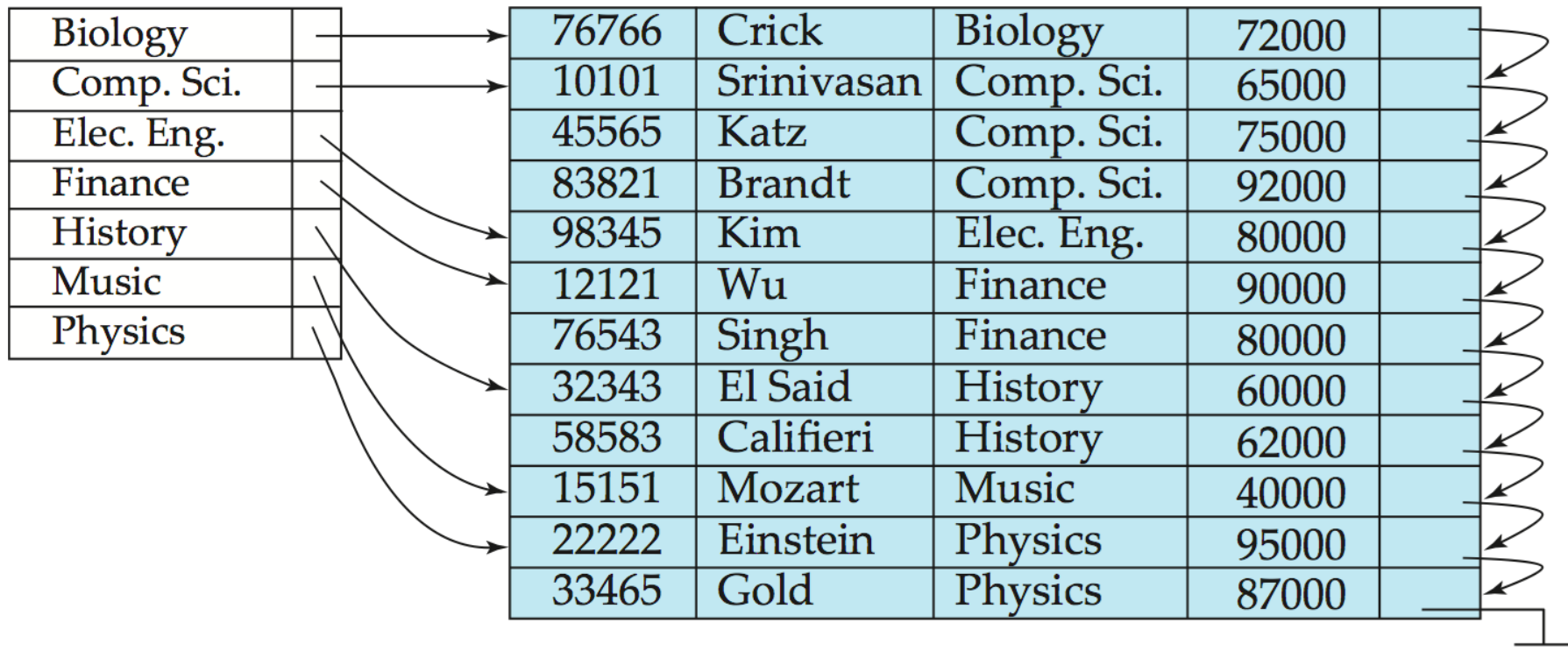

Dense vs. Sparse Index Files

- Sparse Index: contains index records for only some values
 - Applicable when records are sequentially ordered on search-key
- To locate a record with search-key value K we:
 - Find index record with largest search-key value $< K$
 - Search file sequentially starting at that record

or binary
in $[K, K+1)$

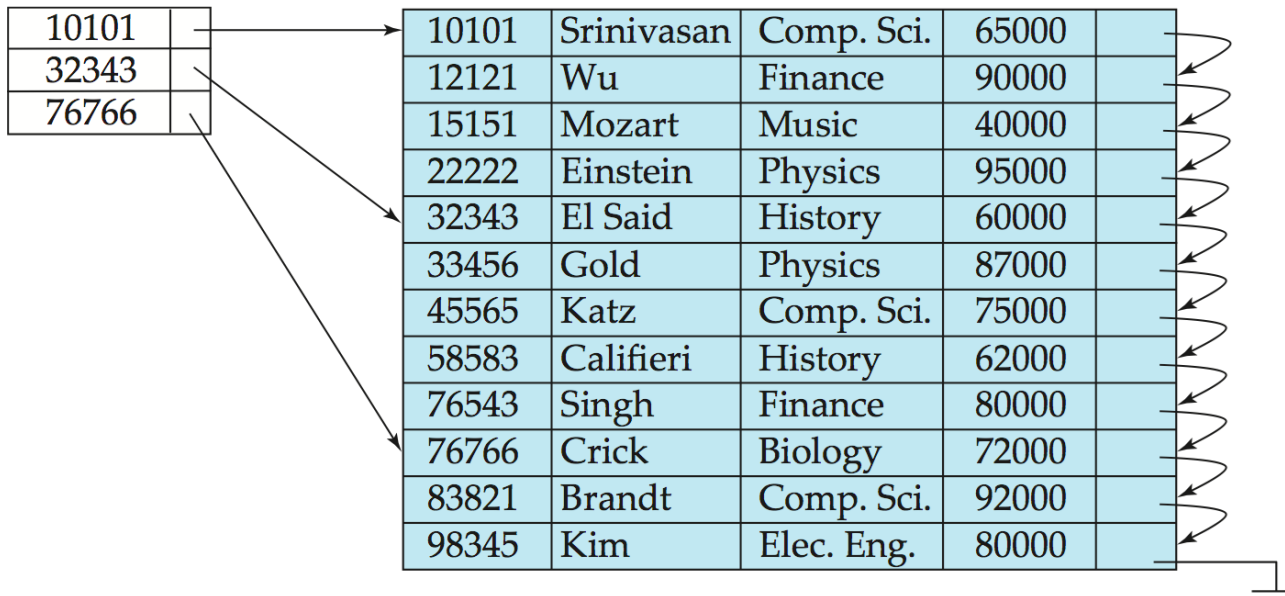

Dense vs. Sparse Index Files

- Dense index
 - Guaranteed search time of $O(\log_2 N)$
 - Requires $O(N)$ storage space
- Sparse index (storing every k-th value)
 - Search time $O(\log_2(N/k) + \log_2 k)$
 - Requires $O(N/k)$ storage space
- Comparison
 - Dense index is faster
 - Sparse index takes less space

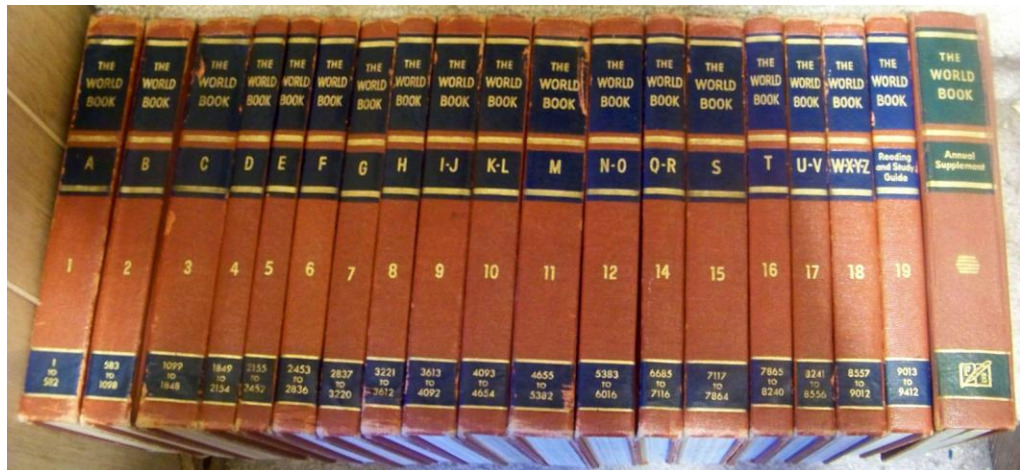
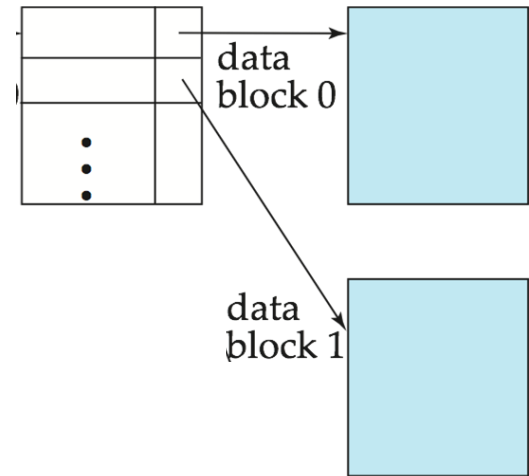

Secondary Index

- A table can only be sorted by one attribute...
- ... but we may need another one in our query
 - Example 1: In the instructor relation stored sequentially by ID, we may want to find all instructors in a particular department
 - Example 2: as above, but where we want to find all instructors with a specified salary or with salary in a specified range of values
- We can have a secondary index with an index record for each search-key value

Secondary Index

- Primary index: index on the attribute by which a file is ordered
- Secondary index: index on any other attribute
 - Index record points to a bucket that contains pointers to all the actual records with that particular search-key value
 - Secondary indices have to be dense why?

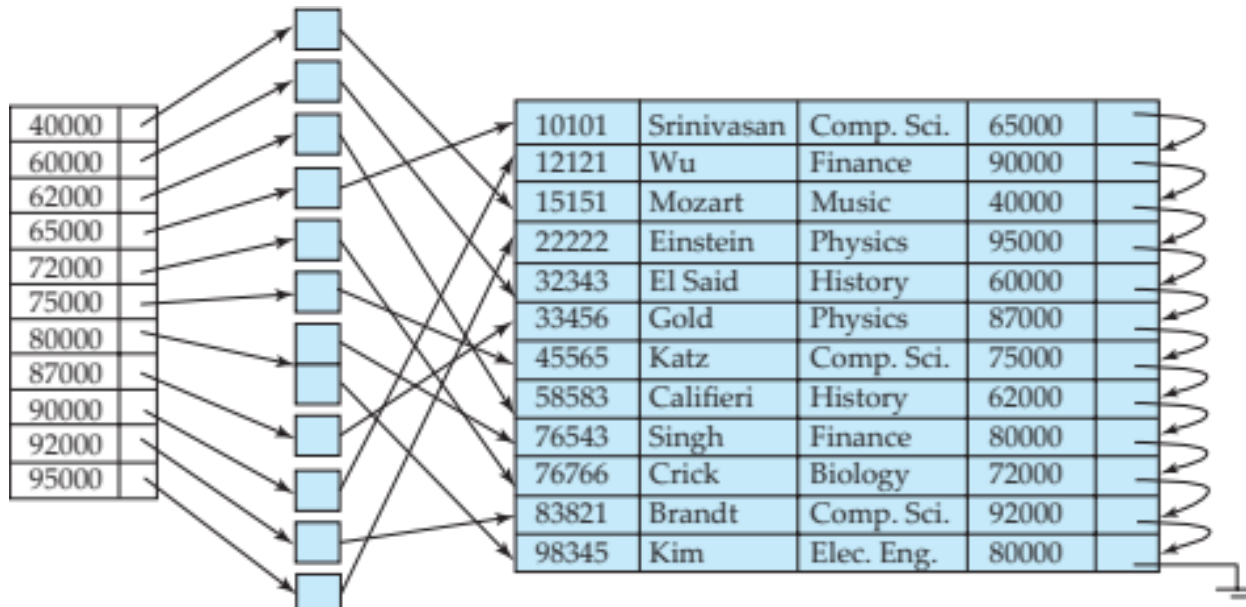

Multi-Level Indices

- Computer storage:
 - RAM: fast, but limited
 - Disk: slow, but large
- Fast access
 - Keep primary index in memory, actual data on disk
- What if the primary index does not fit in memory?
 - Treat primary index kept on disk as a sequential file
 - Construct a sparse index on it, keep that index in memory
- Outer vs. inner index
 - outer index – a sparse index of primary index
 - inner index – the primary index file

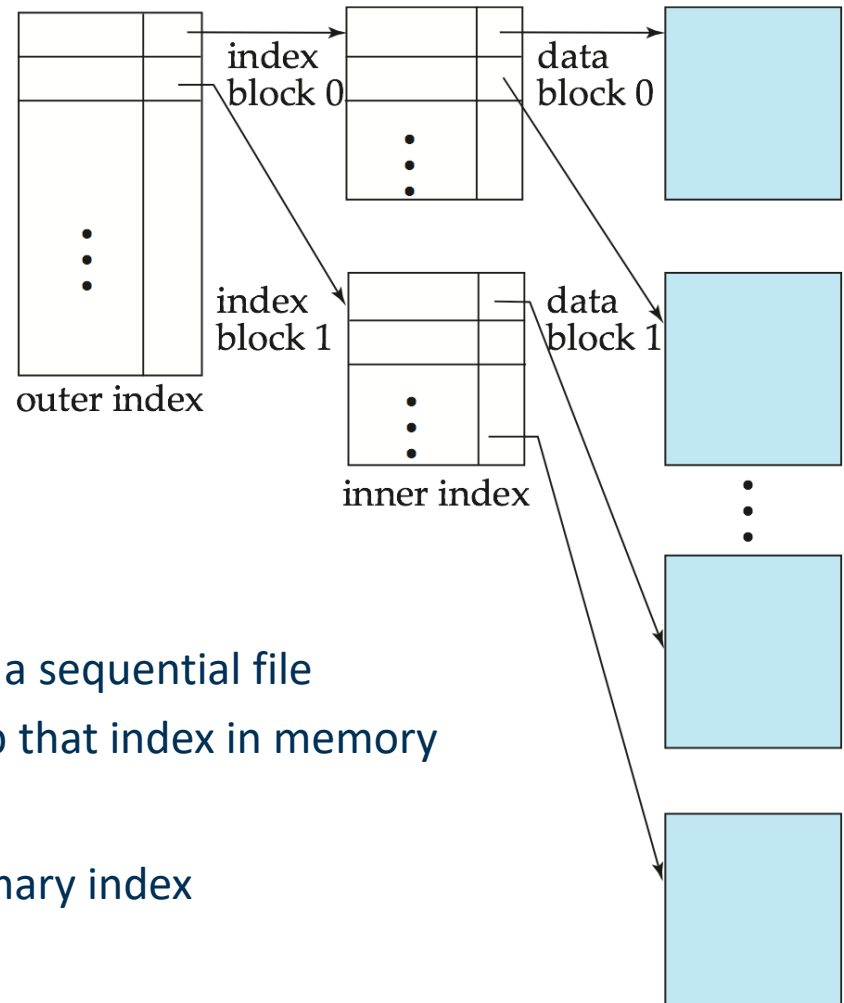

Insertion into Index

- Single-level index insertion
 - Perform a lookup using the search-key value appearing in the record to be inserted
 - Dense indices – if the search-key value does not appear in the index, insert it 
 - Sparse indices – if index stores an entry for each block of the file, no change needs to be made to the index unless a new block is created
 - If a new block is created, the first search-key value appearing in the new block is inserted into the index
- Multilevel insertion: algorithms are simple extensions of the single-level algorithms

Deletion from Index

- If deleted record was the only record in the file with its particular search-key value, the search-key is deleted from the index also
- Single-level index entry deletion:
 - Dense indices – deletion of search-key is similar to file record deletion
 - Sparse indices
 - if an entry for the search key exists in the index, it is deleted by replacing the entry in the index with the next search-key value in the file (in search-key order)
 - If the next search-key value already has an index entry, the entry is deleted instead of being replaced
- Multilevel deletion: algorithms are simple extensions of the single-level algorithms

Summary Sequential Indices

- Access time: $O(\log_2 N)$
- Insertion time: $O(N)$
 - worst case: insertion at the top,
all other entries need to be moved down
- Deletion time: $O(N)$
 - worst case: deletion from the top,
all other entries need to be moved up

B⁺-Tree Index Files

- Disadvantage of indexed-sequential files
 - performance degrades as file grows, since many overflow blocks get created
 - periodic reorganization of entire file is required
- Advantage of B⁺-tree index files:
 - automatically reorganizes itself with small, local, changes, in the face of insertions and deletions
 - reorganization of entire file is not required to maintain performance
- (Minor) disadvantage of B⁺-trees:
 - extra insertion and deletion overhead, space overhead
- Advantages of B⁺-trees outweigh disadvantages
- B⁺-trees are used extensively

B⁺-Trees

- A B⁺-tree is a rooted tree satisfying the following properties:
 - All paths from root to leaf are of the same length
 - Each node that is not a root or a leaf has between $\lceil n/2 \rceil$ and n children
 - A leaf node has between $\lceil (n-1)/2 \rceil$ and $n-1$ values
- Special cases:
 - If the root is not a leaf, it has at least 2 children.
 - If the root is a leaf (that is, there are no other nodes in the tree), it can have between 0 and $(n-1)$ values.



B⁺-Trees: Example

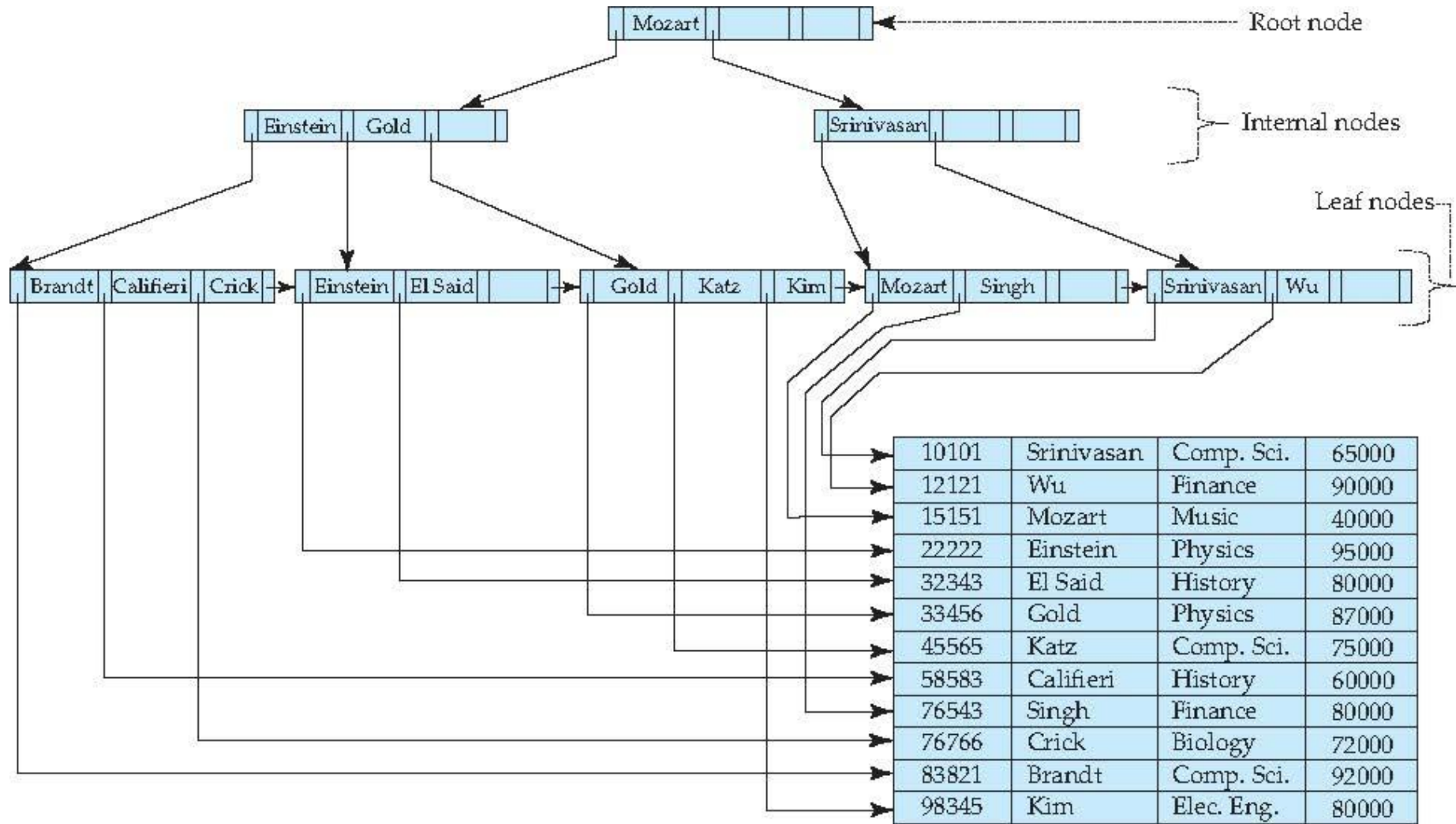

B⁺-Trees: Example

- Example: $n=4$
 - All paths from root to leaf are of the same length
 - Each node that is not a root or a leaf has between $\lceil n/2 \rceil = 2$ and $n=4$ children
 - A leaf node has between $\lceil (n-1)/2 \rceil = 2$ and $n-1=3$ values
 - Root has at least 2 children

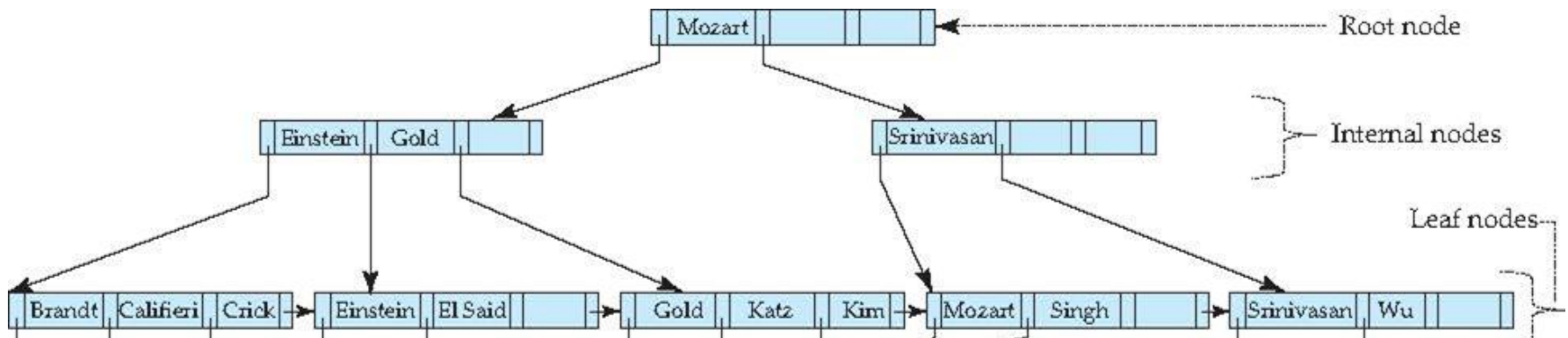

B⁺-Tree Node Structure

- Typical node

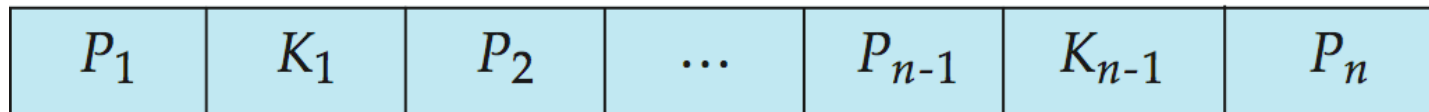

- K_i are the search-key values
- P_i are pointers to children (for non-leaf nodes)
or pointers to records or buckets of records (for leaf nodes)
- The search-keys in a node are ordered
- $$K_1 < K_2 < K_3 < \dots < K_{n-1}$$
 - for the moment: assuming there are no duplicate keys,
but extension to handling duplicate keys is easily possible

Leaf Nodes in B⁺-Trees

- For $i = 1, 2, \dots, n-1$, pointer P_i points to a file record with search-key value K_i ,
- If L_i, L_j are leaf nodes and $i < j$, L_i 's search-key values are less than or equal to L_j 's search-key values
- P_n points to next leaf node in search-key order

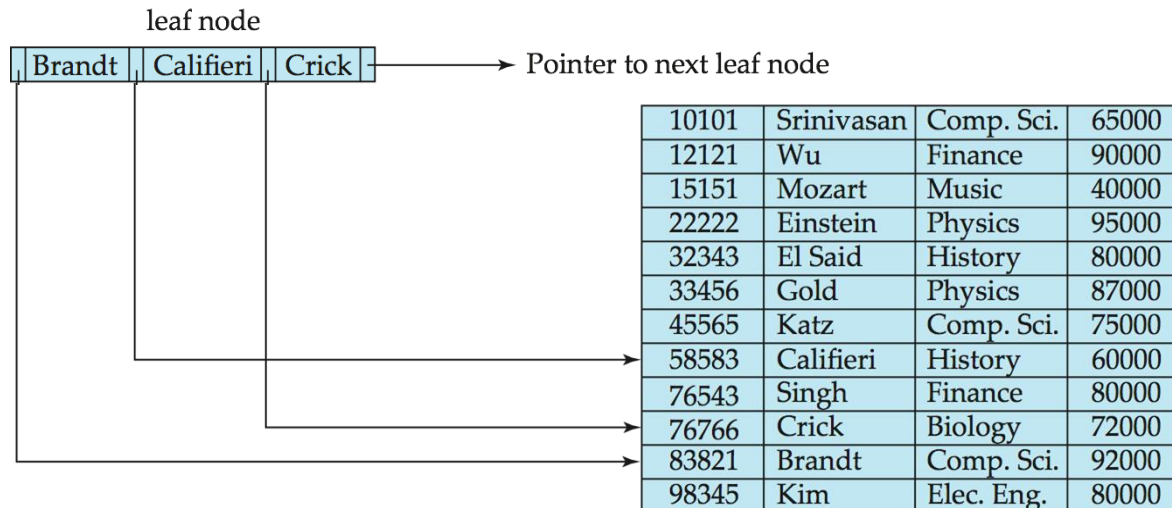

Inner Nodes in B⁺-Trees

- Properties of an inner node with m entries:
 - All the search-keys in the subtree to which P_1 points are less than K_1
 - For $2 \leq i \leq n - 1$, all the search-keys in the subtree to which P_i points have values greater than or equal to K_{i-1} and less than K_i
 - All the search-keys in the subtree to which P_n points have values greater than or equal to K_{n-1}

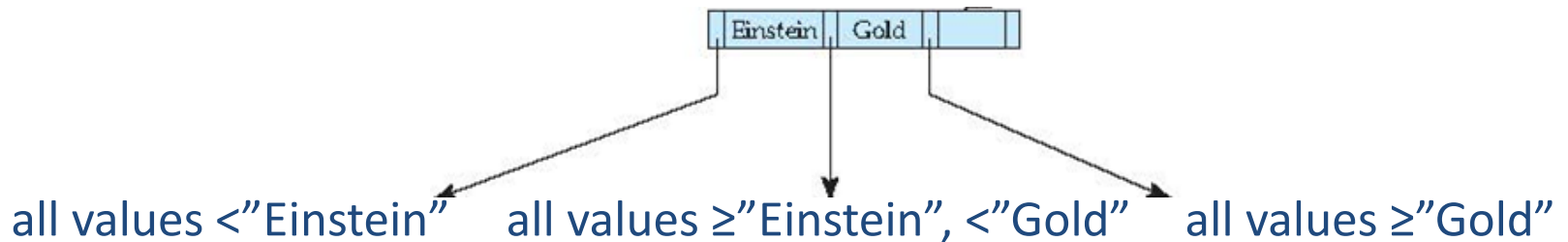
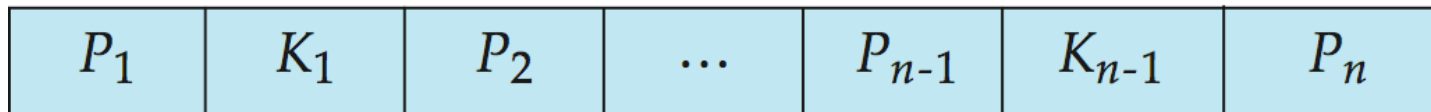

Observations about B⁺-Trees

- Inter-node connections are done by pointers
 - “logically” close blocks need not be “physically” close!
- Non-leaf levels of the B⁺-tree form a hierarchy of sparse indices
- B⁺-tree contains a relatively small number of levels
 - Level below root has at least $2 * \lceil n/2 \rceil$ values
 - Next level has at least $2 * \lceil n/2 \rceil * \lceil n/2 \rceil$ values
 - ... etc.
 - If there are K search-key values in the file, the tree height is no more than $\lceil \log_{\lceil n/2 \rceil}(K) \rceil$
 - searches can be conducted efficiently
- Insertions and deletions to the main file can be handled efficiently (as we shall see)

Querying B⁺-Trees

- Given a search value V (e.g., “Einstein”)
 - In non-leaf nodes: follow non-null pointers P_i where $V < K_i$, so that i maximal
 - In leaf nodes: if there is a value $K_i = V$, follow P_i
 - else: record does not exist

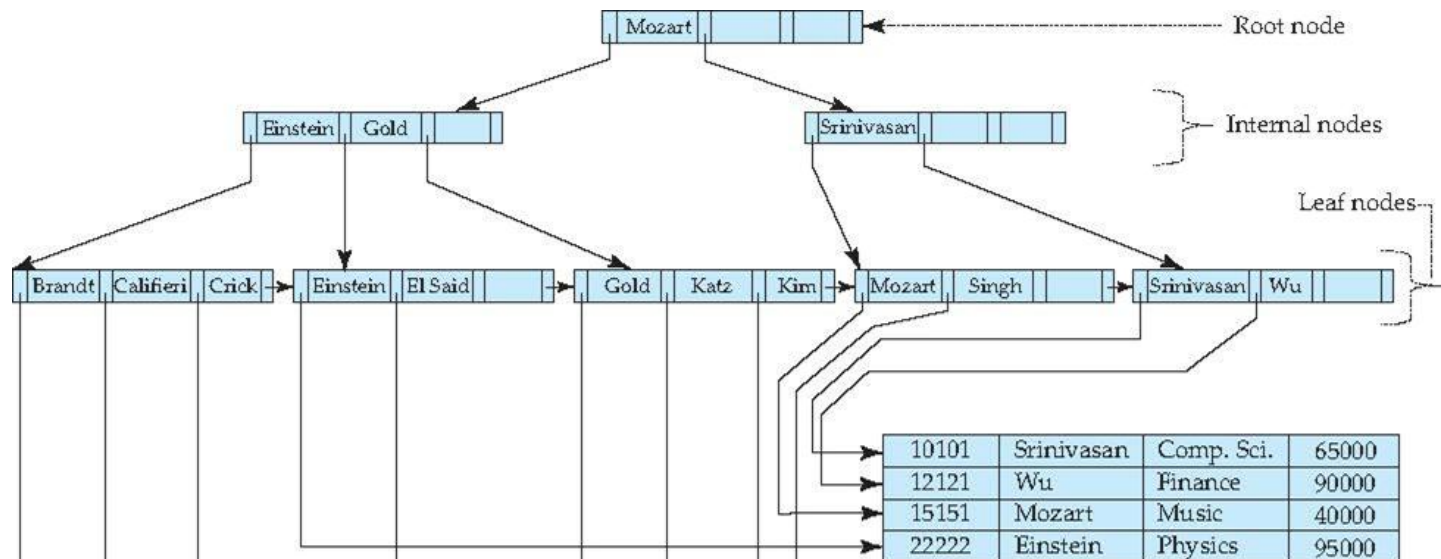

Querying B⁺-Trees

- If there are K search-key values in the file, the height of the tree is no more than $\lceil \log_{\lceil n/2 \rceil}(K) \rceil$
 - i.e., this is the number of leaf nodes to inspect
 - supposing a disk-based index: the number of nodes to be retrieved
- A node is generally the same size as a disk block, typically 4 kilobytes
 - and n is typically around 100 (40 bytes per index entry)
- With 1 million search key values and $n = 100$
 - at most $\log_{50}(1,000,000) = 4$ nodes are accessed in a lookup

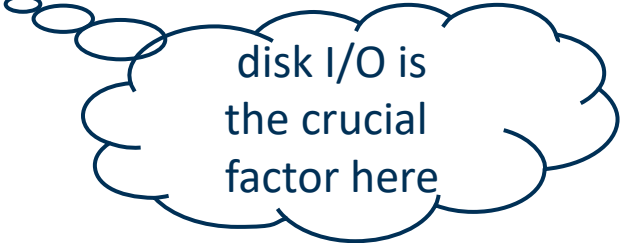

disk I/O is
the crucial
factor here

Updates on B⁺-Trees: Insertion

- Find the leaf node in which the search-key value would appear
- If the search-key value is already present in the leaf node
 - add record to the file
 - if necessary, add a pointer to the bucket
- If the search-key value is not present, then
 - add the record to the main file (and create a bucket if necessary)
 - If there is room in the leaf node
 - insert (key-value, pointer) pair in the leaf node
 - else
 - split the node (along with the new (key-value, pointer) entry)



Updates on B⁺-Trees: Insertion

- Splitting a leaf node:
 - take the n (search-key value, pointer) pairs (including the one being inserted) in sorted order. Place the first $\lceil n/2 \rceil$ in the original node, and the rest in a new node p
 - let k be the least key value in p . Insert (k,p) in the parent of the node being split.
 - If the parent is full, split it and **propagate** the split further up
- Splitting of nodes proceeds upwards till a node that is not full is found
 - In the worst case (i.e., root is full) the root node may be split increasing the height of the tree by 1

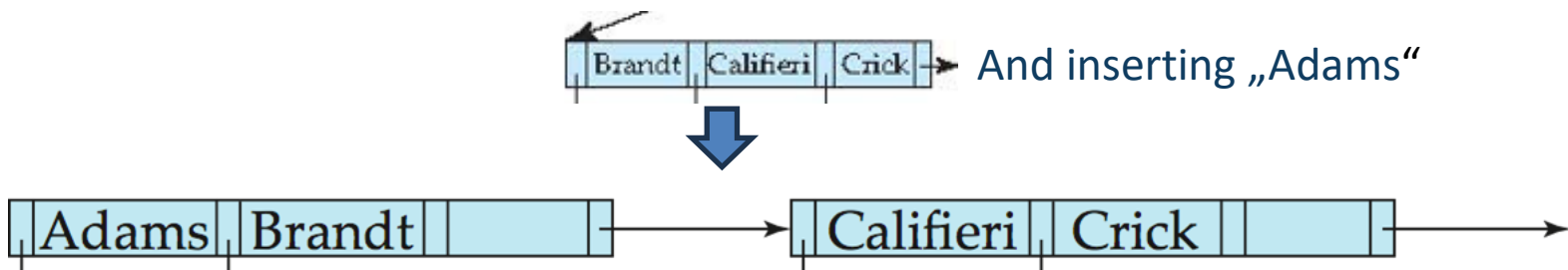

Next step: insert entry with (Califieri, pointer-to-new-node) into parent

Updates on B⁺-Trees: Insertion

- Inserting “Adams”

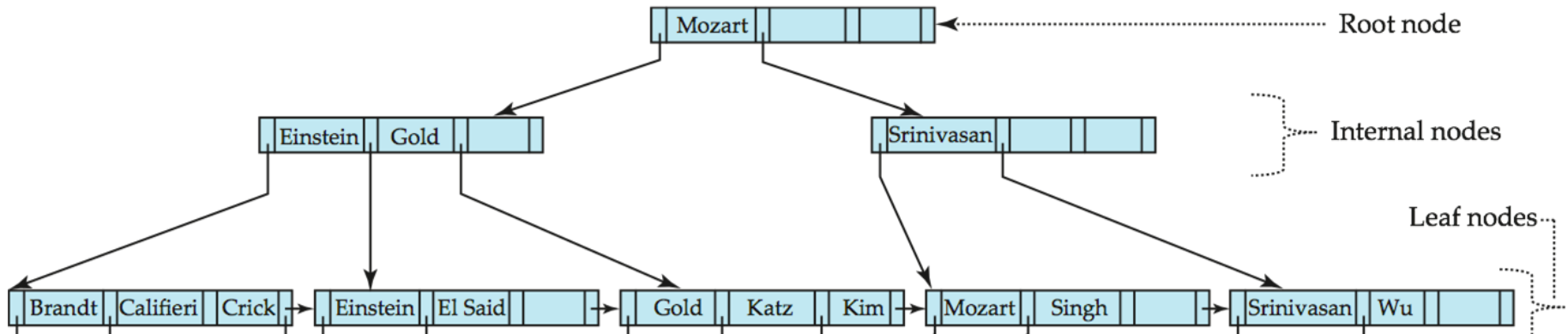

Affected Nodes

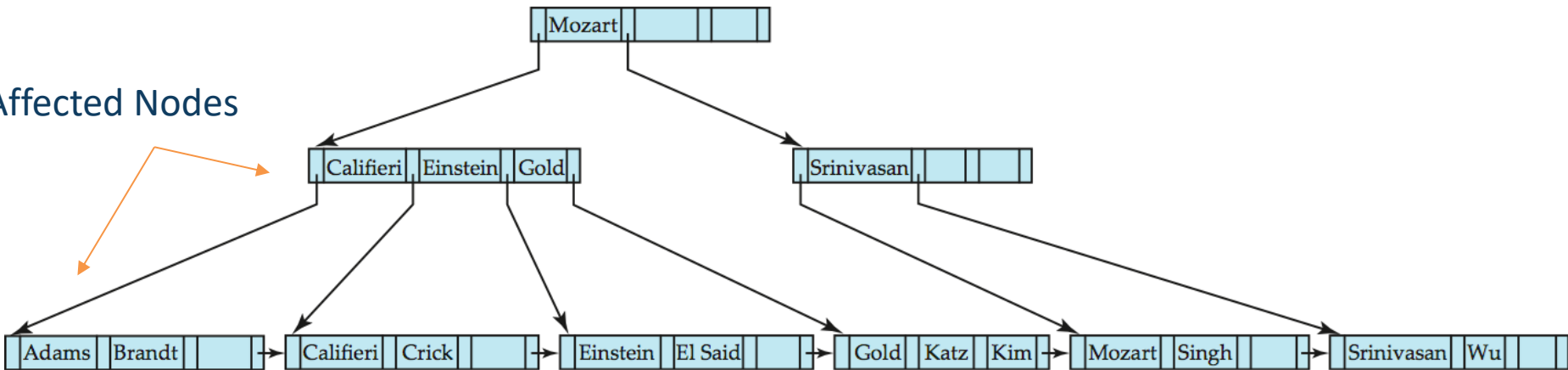

Updates on B⁺-Trees: Insertion

- Inserting “Lampport”

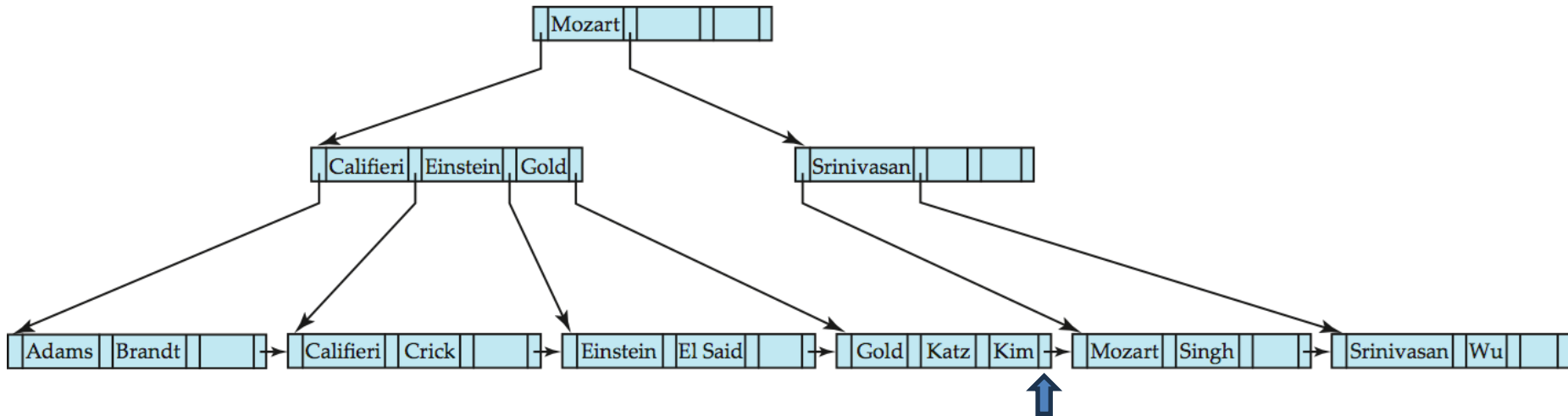

- Leaf node is full
 - Kim and Lampport are in a new leaf node and Kim needs to be inserted into non-leaf node

Updates on B⁺-Trees: Insertion

- Adding „Kim“ into **non-leaf** node
- Splitting a non-leaf node is a bit different

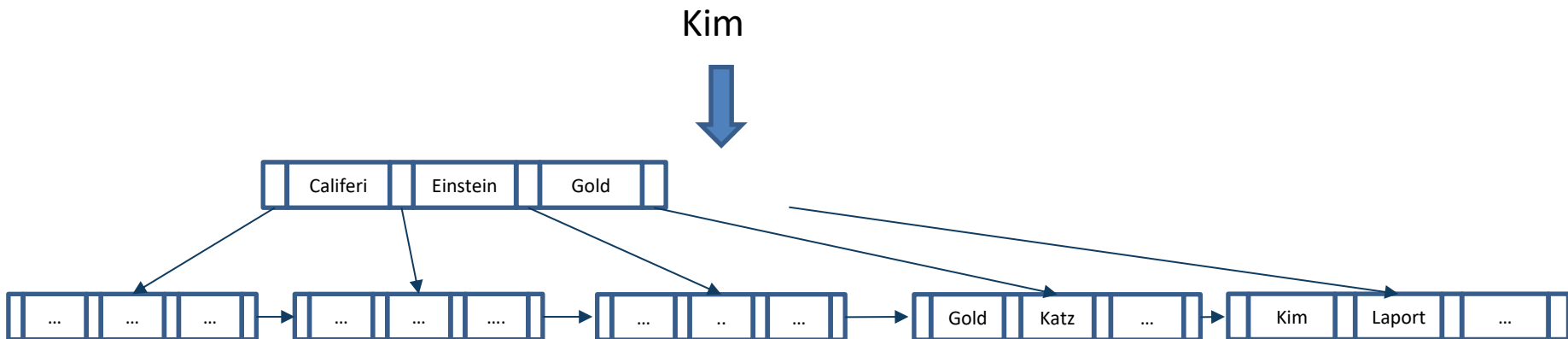

Updates on B⁺-Trees: Insertion

- Adding „Kim“ into **non-leaf** node
- Splitting a non-leaf node is a bit different
 - Assume we have space for n (in this case 5) keys
 - Leave $P_1, K_1, \dots, K_{\lceil n/2 \rceil - 1}, P_{\lceil n/2 \rceil}$ in node N
 - Copy $P_{\lceil n/2 \rceil + 1}, K_{\lceil n/2 \rceil + 1}, \dots, K_n, P_{n+1}$ into newly allocated node N'
 - Insert $(K_{\lceil n/2 \rceil}, N')$ into parent

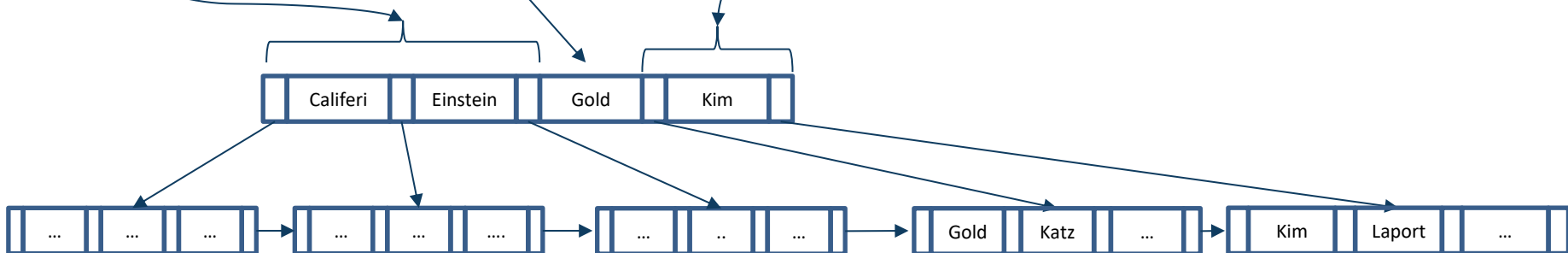

Updates on B⁺-Trees: Insertion

- Adding „Kim“ into **non-leaf** node
- Splitting a non-leaf node is a bit different
 - Assume we have space for n (in this case 5) keys
 - Leave $P_1, K_1, \dots, K_{\lceil n/2 \rceil - 1}, P_{\lceil n/2 \rceil}$ in node N
 - Copy $P_{\lceil n/2 \rceil + 1}, K_{\lceil n/2 \rceil + 1}, \dots, K_n, P_{n+1}$ into newly allocated node N'
 - Insert $(K_{\lceil n/2 \rceil}, N')$ into parent

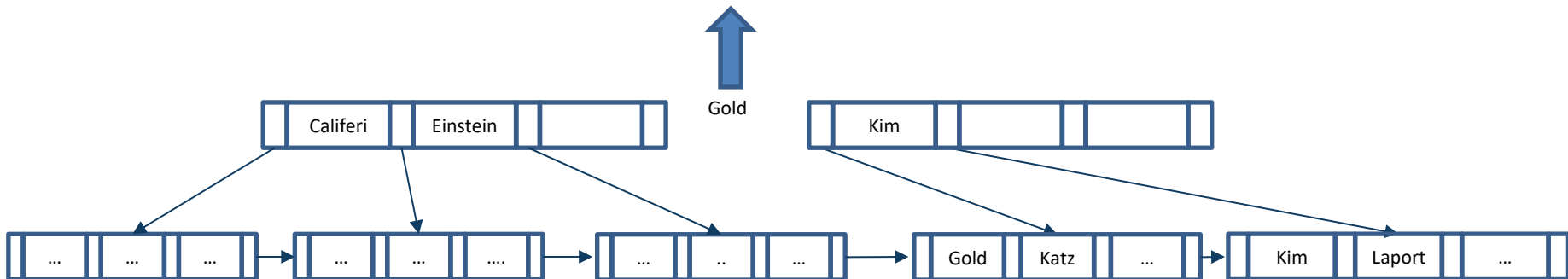

Updates on B⁺-Trees: Insertion

- Inserting “Lampport”

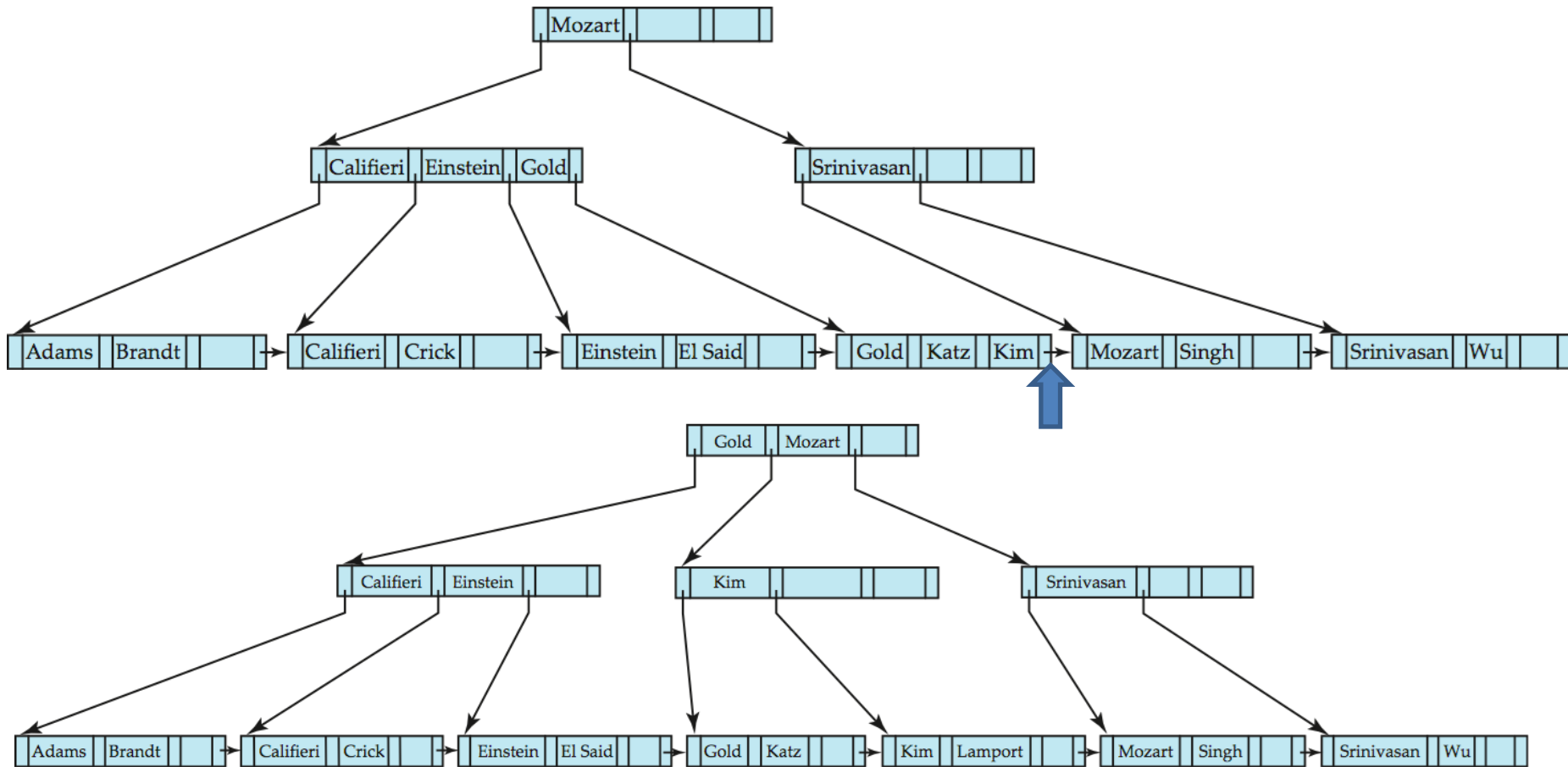

Updates on B⁺-Trees: Deletion

- Find the record to be deleted, and remove it from the main file and from the bucket (if present)
- Remove (search-key value, pointer) from the leaf node if there is no bucket or if the bucket has become empty
- If the node has too few entries due to the removal, and the entries in the node and a sibling fit into a single node, then **merge siblings**
- Otherwise, if the node has too few entries due to the removal, but the entries in the node and a sibling do not fit into a single node, then **redistribute pointers**

Updates on B⁺-Trees: Deletion

- Deleting “Srinivasan”

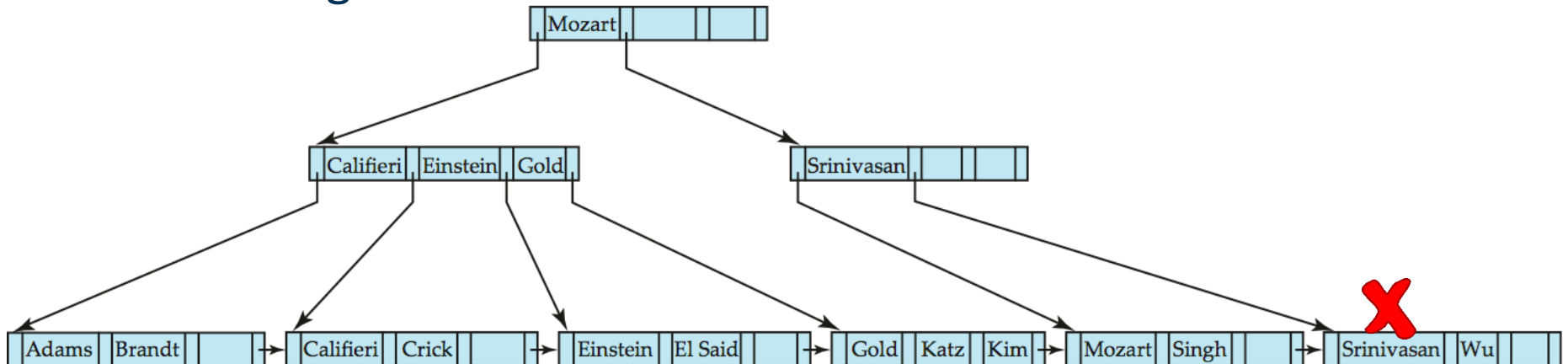

Updates on B⁺-Trees: Deletion

- Deleting “Srinivasan”

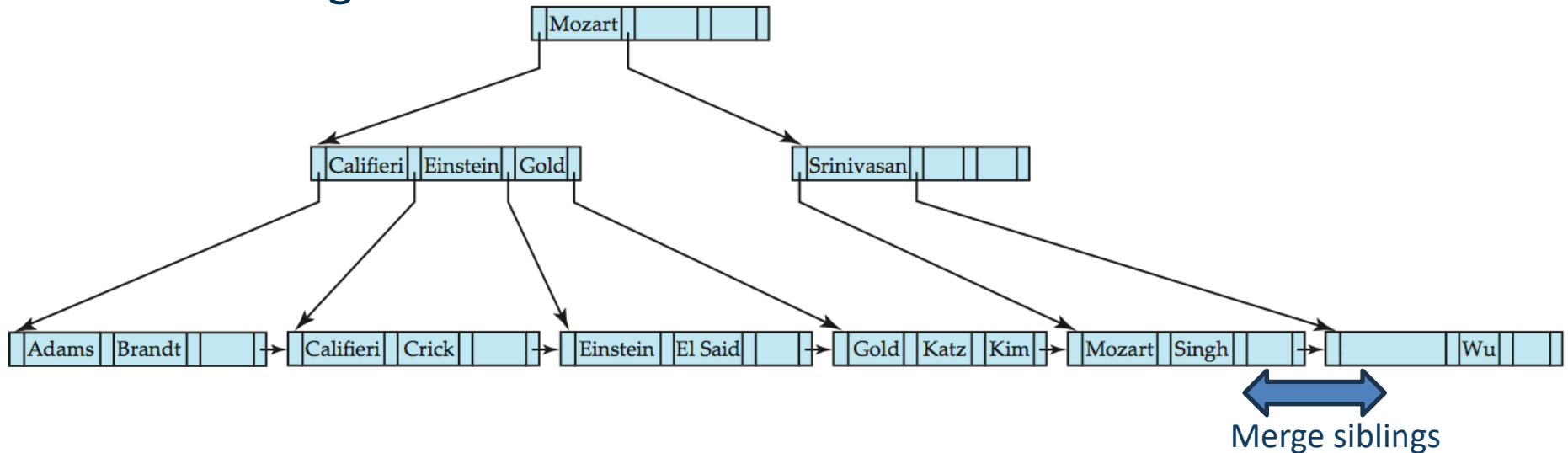

- **Merge siblings:**

- Insert all the search-key values in the two nodes into a single node, and delete the other node
- Delete the pair (K_{i-1}, P_i) , where P_i is the pointer to the deleted node, from its parent, recursively using the above procedure

Updates on B⁺-Trees: Deletion

- Deleting “Srinivasan”

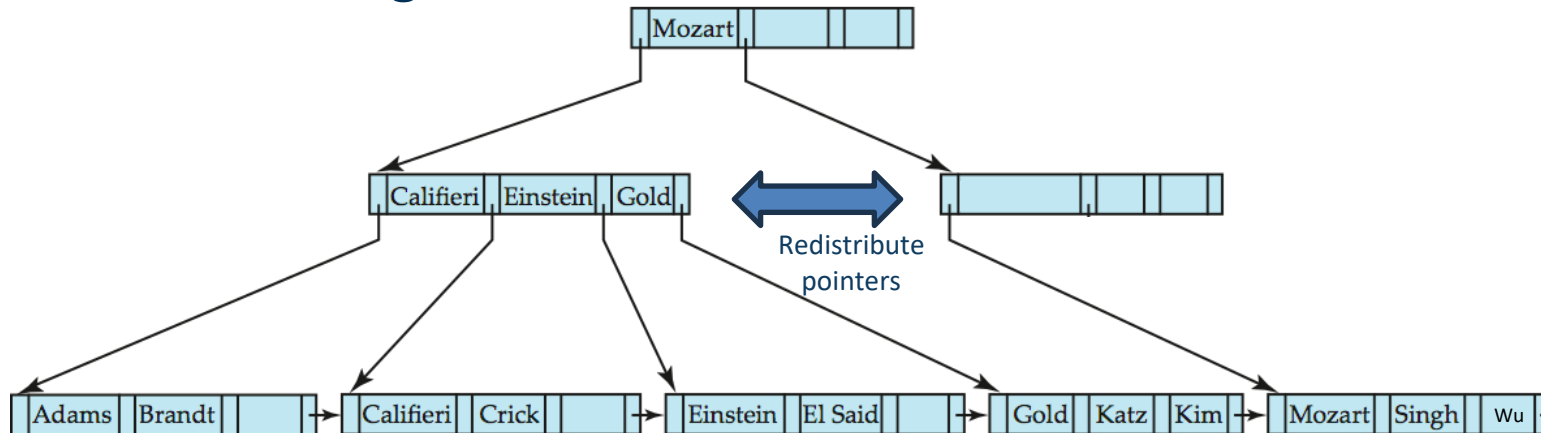

- Merge siblings not possible -> redistribute pointers
- **Redistribute pointers:**
 - Redistribute the pointers between the node and a sibling such that both have more than the minimum number of entries.
 - Update the corresponding search-key value in the parent of the node.

Updates on B⁺-Trees: Deletion

- Deleting “Srinivasan”

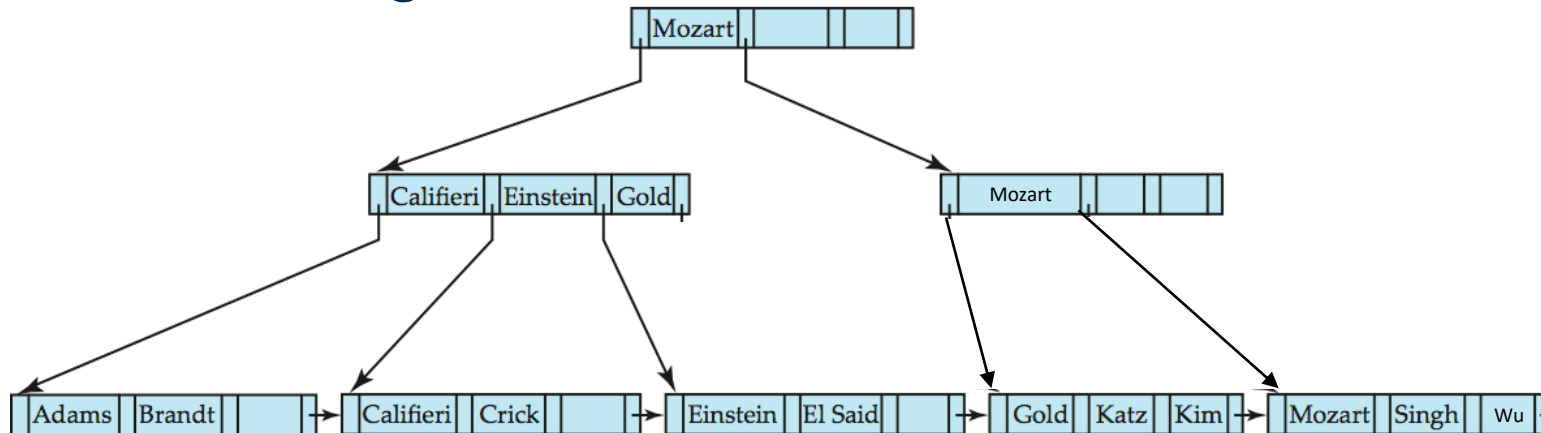

- New value separating them is Mozart (present in the root node)
 - Mozart in the root node no longer correctly separates values in siblings

Updates on B⁺-Trees: Deletion

- Deleting “Srinivasan”

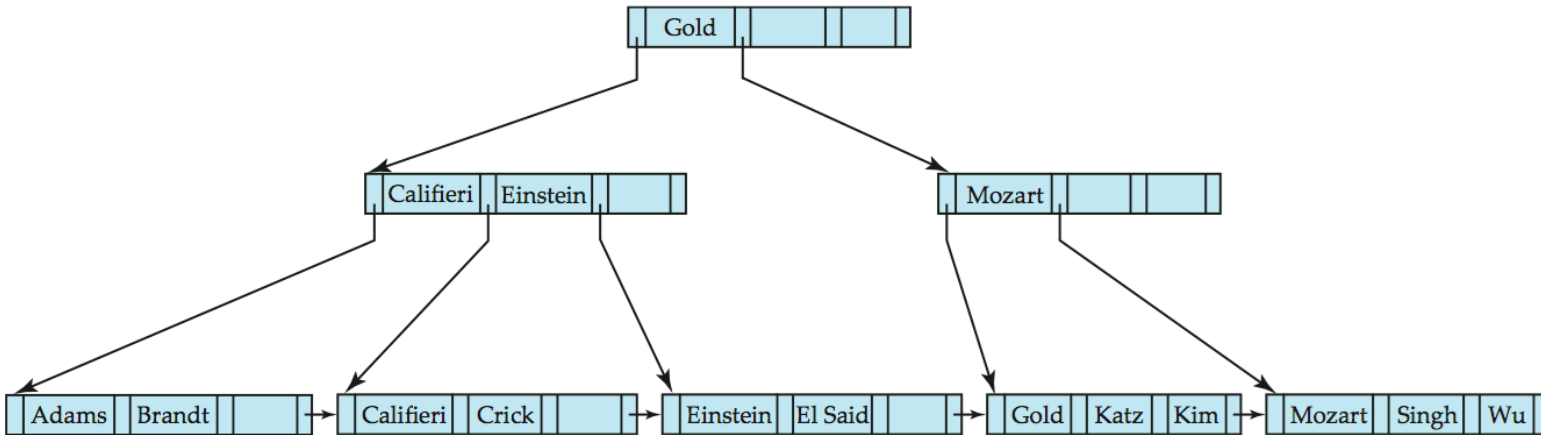

- Use Gold as a new value in the root node

Indexing vs. Hashing

- Index structures:
 - Look up value
 - Retrieve storage location (e.g., row number in table)
- Hashing:
 - Compute storage location directly from the value using a *hash function*

Static Hashing

- Bucket: unit of storage containing one or more records
 - Typically: a disk block
- Hash function $h(x)$:
maps a search key to the block where the record is located
 - $h : K \rightarrow B$
 - Records with different search-key values
may be mapped to the same bucket
 - bucket has to be searched sequentially to eventually locate a record
 - bucket overflow occurs when a bucket is full

Example for a Hash Function

- There are 10 buckets
- The hash function maps a department name to numbers between 0-9
- e.g., $h(\text{Music}) = 1$ $h(\text{History}) = 2$
 $h(\text{Physics}) = 3$ $h(\text{Elec. Eng.}) = 3$

bucket 0

bucket 1

15151	Mozart	Music	40000

bucket 2

32343	El Said	History	80000
58583	Califieri	History	60000

bucket 3

22222	Einstein	Physics	95000
33456	Gold	Physics	87000
98345	Kim	Elec. Eng.	80000

Hash Functions

- A hash function should be
 - *uniform*, i.e., each bucket is assigned the same number of search-key values
 - *random*, i.e., the size of buckets should be independent of the actual distribution of search-key values
 - e.g., language is not uniformly distributed
- Worst case: all search-key values map to the same bucket
 - access time proportional to the number of search-key values in the file

Bucket Overflow

- **Overflow chaining (also called closed hashing)**
 - the overflow buckets of a given bucket are chained together in a linked list
 - slows search for actual record
 - cannot be entirely avoided, but reduced by good choice of hash function

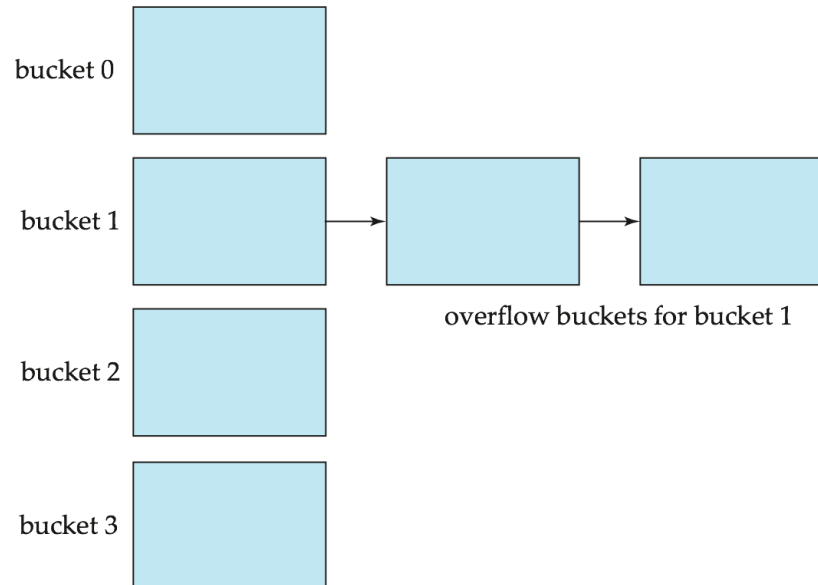

Hash Indices

- Hashing can be used not only for file organization, but also for index-structure creation
 - A **hash index** organizes the search keys, with their associated record pointers, into a hash file structure

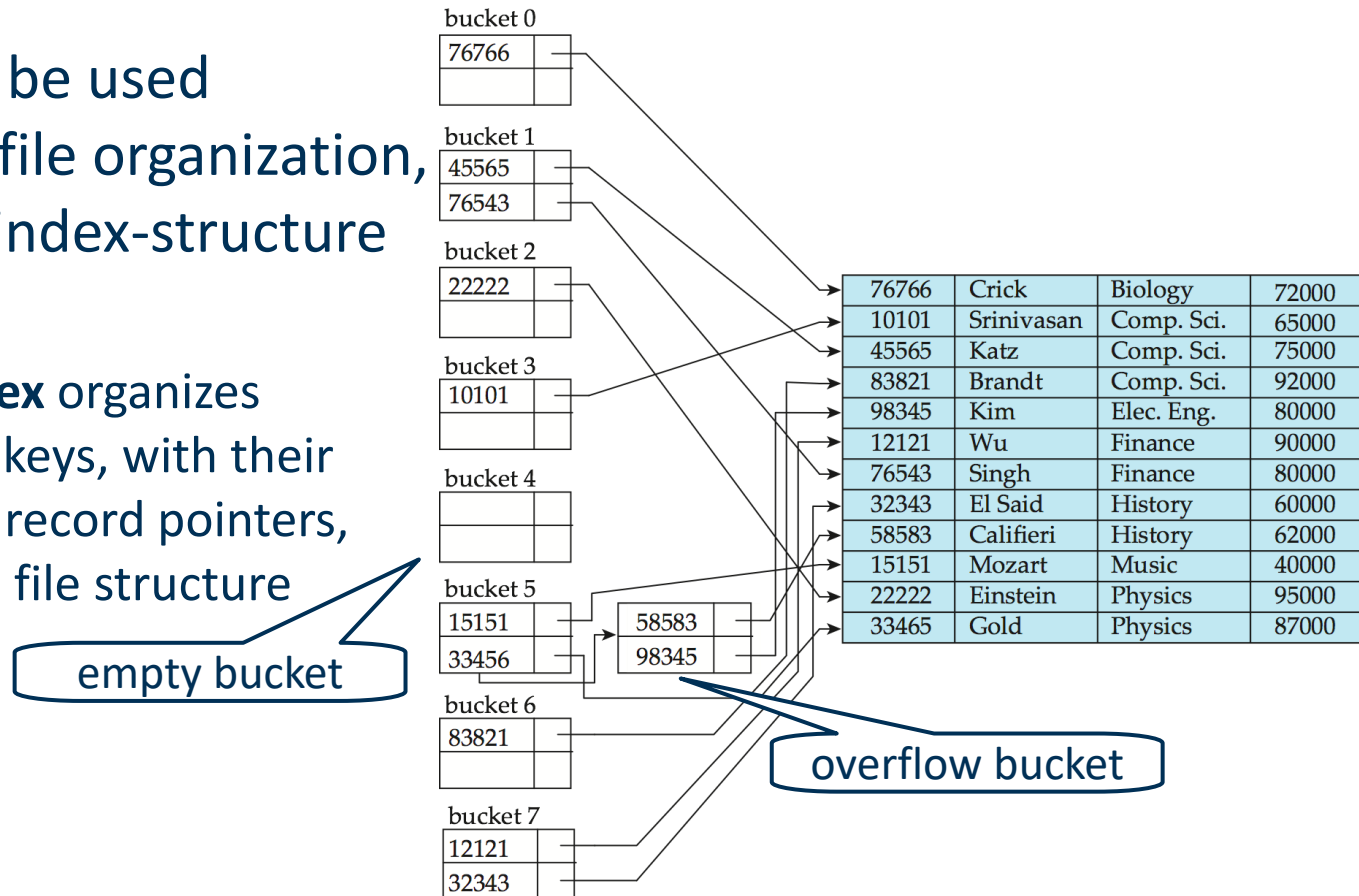

Drawbacks of Static Hashing

- In static hashing, function h maps search-key values to a fixed set of B of bucket addresses
 - But databases may grow or shrink over time
- Growing database
 - performance degrades due to many overflow buckets
- Shrinking database
 - space is wasted by underfull buckets
- Possible solution:
periodic re-organization of the file with a new hash function
 - Expensive, disrupts normal operations
- Better solution
 - allow the number of buckets to be modified dynamically
 - aka *dynamic hashing*

Dynamic Hashing

- Good for database that grows and shrinks in size
- Allows the hash function to be modified dynamically
- **Extendable hashing** – one form of dynamic hashing
 - Hash function generates values over a large range
 - typically b -bit integers, e.g., $b = 32$.
- At any time use only a prefix of the hash function to index into a table of bucket addresses
 - Let the length of the prefix be i bits, $0 \leq i \leq 32$.
 - Bucket address table size = 2^i . Initially $i = 0$
- Value of i grows and shrinks as the size of the database grows and shrinks
- Multiple entries in the bucket address table may point to a bucket (why?)
 - Thus, actual number of buckets is $< 2^i$
 - Number of buckets also changes dynamically by merging and splitting buckets

Extendable Hash Structure

- Example:
 - more hash values with prefix “1” than with prefix “0”

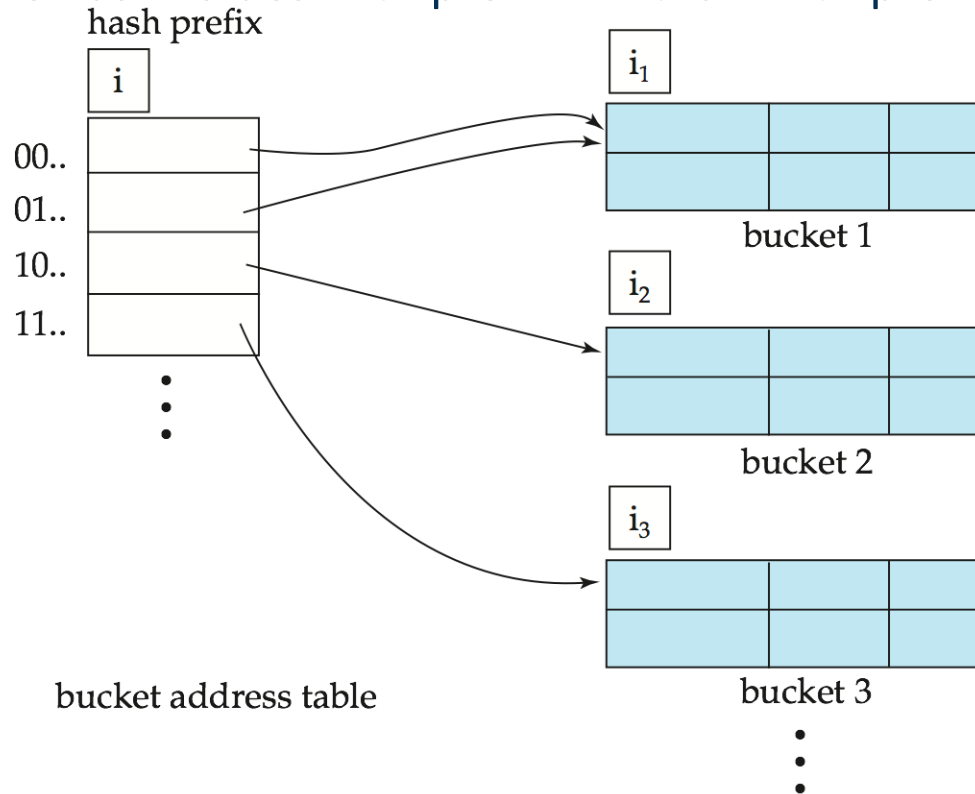

Extendable Hashing

- Each bucket j stores a value i_j
- All the entries that point to the same bucket have the same values on the first i_j bits
- To locate the bucket containing search-key K_j :
 1. Compute $h(K_j) = X$
 2. Use the first i bits of X as a displacement into bucket address table, and follow the pointer to appropriate bucket
- Insertion and deletion may cause splitting/merging of buckets
- Overflow buckets may still be needed for key collisions

Extendable Hashing – Example

- Bucket size: 2

<i>dept_name</i>	<i>h(dept_name)</i>
Biology	0010 1101 1111 1011 0010 1100 0011 0000
Comp. Sci.	1111 0001 0010 0100 1001 0011 0110 1101
Elec. Eng.	0100 0011 1010 1100 1100 0110 1101 1111
Finance	1010 0011 1010 0000 1100 0110 1001 1111
History	1100 0111 1110 1101 1011 1111 0011 1010
Music	0011 0101 1010 0110 1100 1001 1110 1011
Physics	1001 1000 0011 1111 1001 1100 0000 0001

Bucket 0

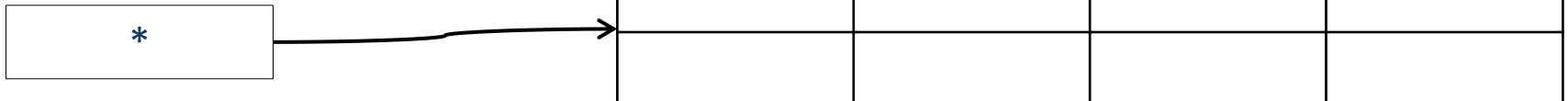

Extendable Hashing – Example

- After insertion of Mozart, Srinivisan, Wu

<i>dept_name</i>	<i>h(dept_name)</i>
Biology	0010 1101 1111 1011 0010 1100 0011 0000
Comp. Sci.	1111 0001 0010 0100 1001 0011 0110 1101
Elec. Eng.	0100 0011 1010 1100 1100 0110 1101 1111
Finance	1010 0011 1010 0000 1100 0110 1001 1111
History	1100 0111 1110 1101 1011 1111 0011 1010
Music	0011 0101 1010 0110 1100 1001 1110 1011
Physics	1001 1000 0011 1111 1001 1100 0000 0001

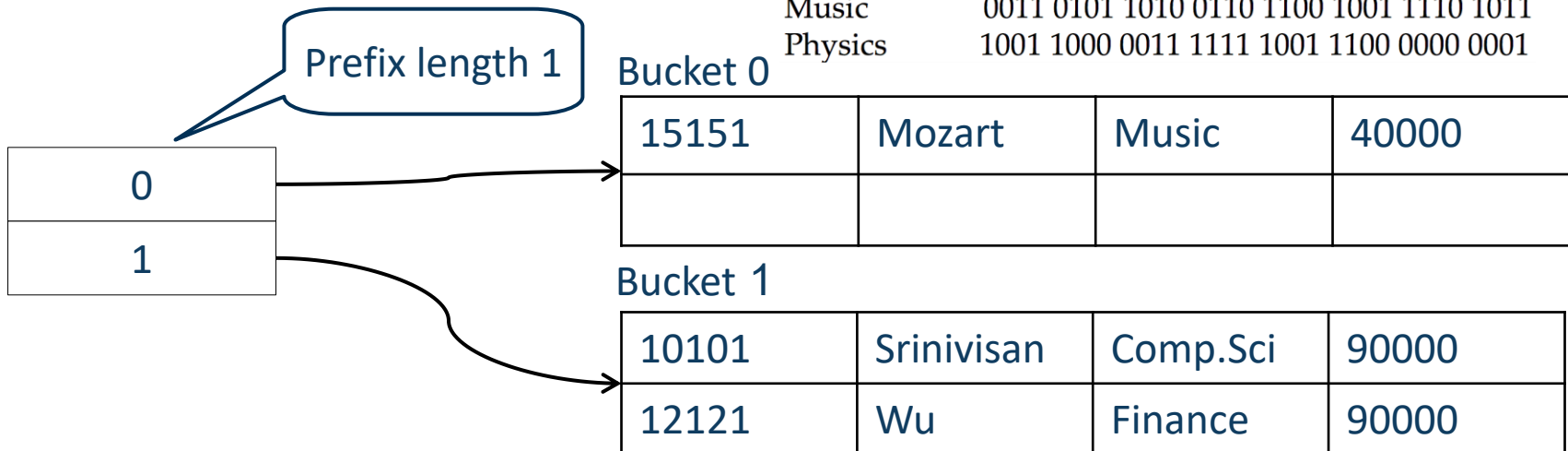

Extendable Hashing – Example

- After insertion of Einstein

Pointers to same bucket

<i>dept_name</i>	<i>h(dept_name)</i>
Biology	0010 1101 1111 1011 0010 1100 0011 0000
Comp. Sci.	1111 0001 0010 0100 1001 0011 0110 1101
Elec. Eng.	0100 0011 1010 1100 1100 0110 1101 1111
Finance	1010 0011 1010 0000 1100 0110 1001 1111
History	1100 0111 1110 1101 1011 1111 0011 1010
Music	0011 0101 1010 0110 1100 1001 1110 1011
Physics	1001 1000 0011 1111 1001 1100 0000 0001

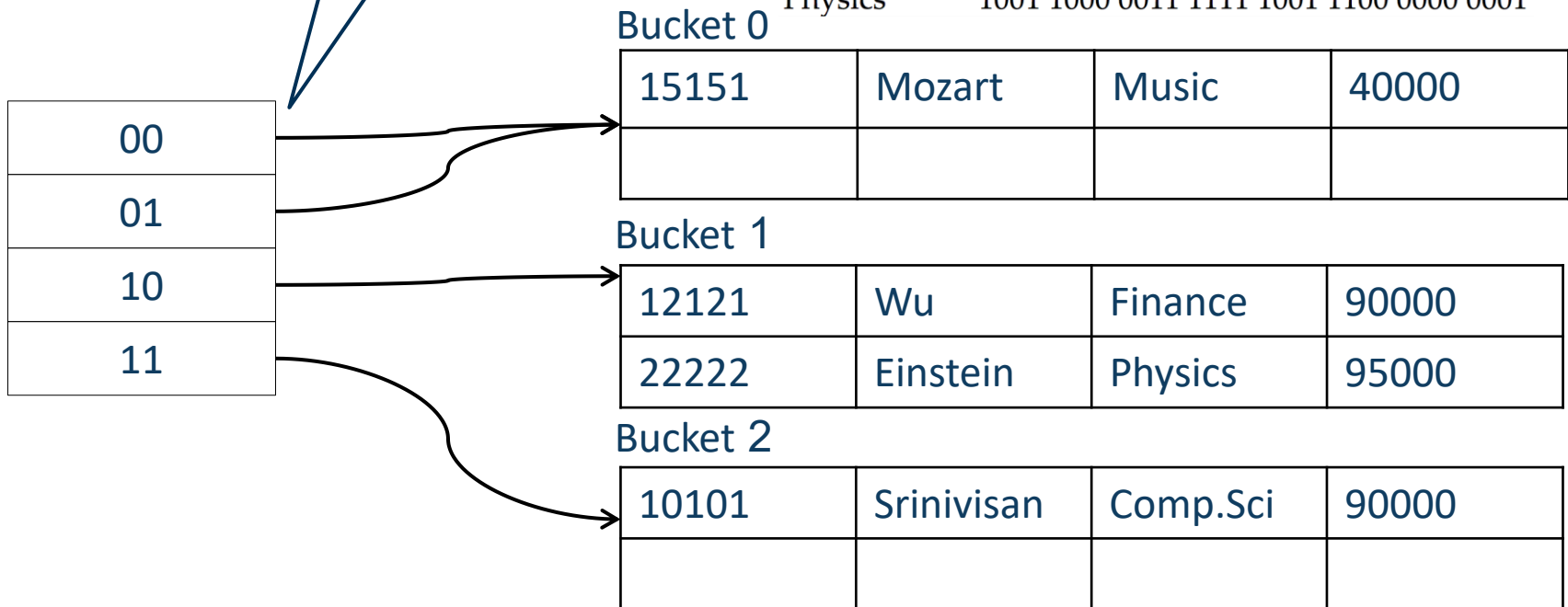

Extendable Hashing – Example

- After insertion of Gold, El Said

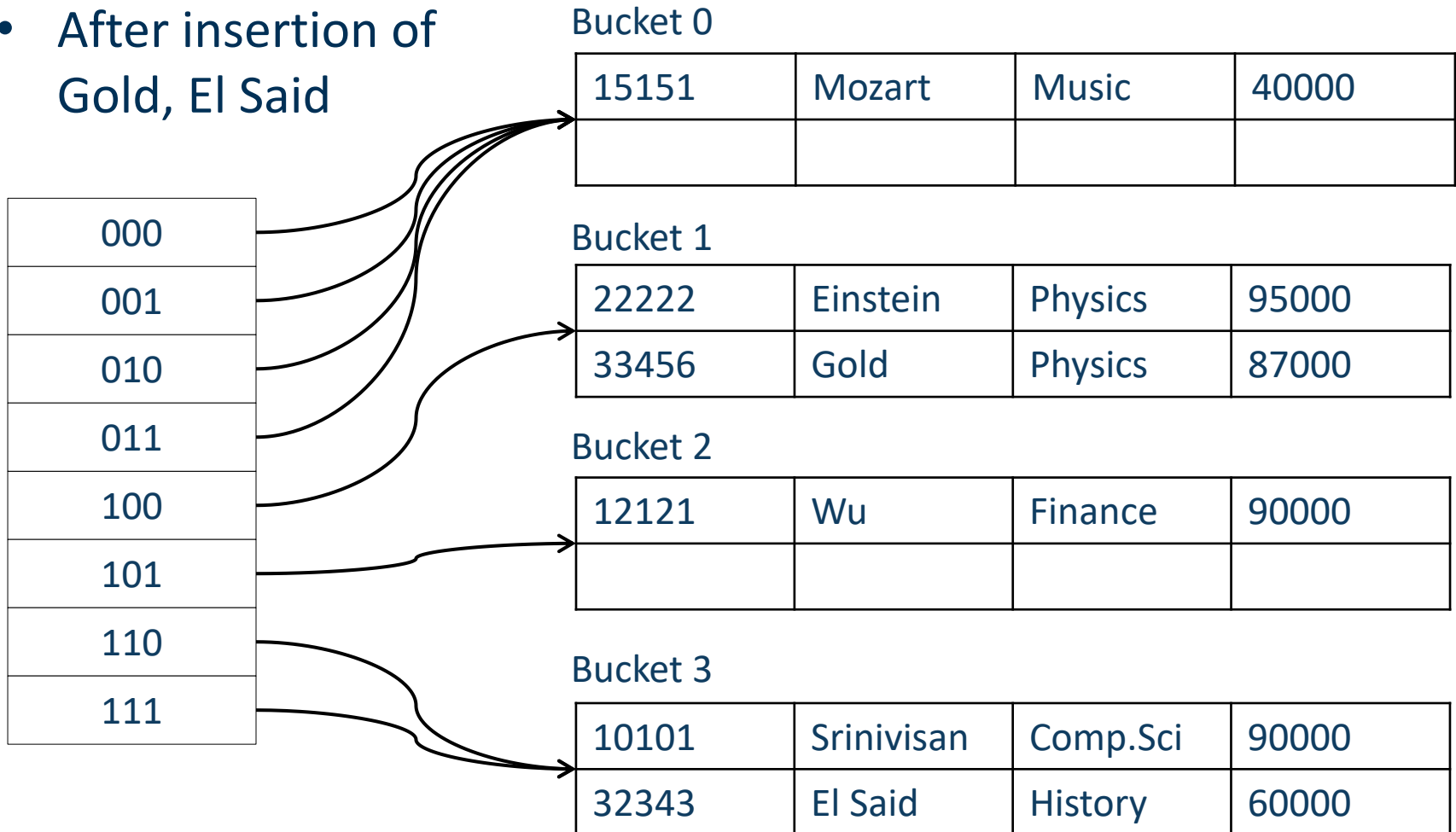

Extendable Hashing – Example

- After inserting Feinman

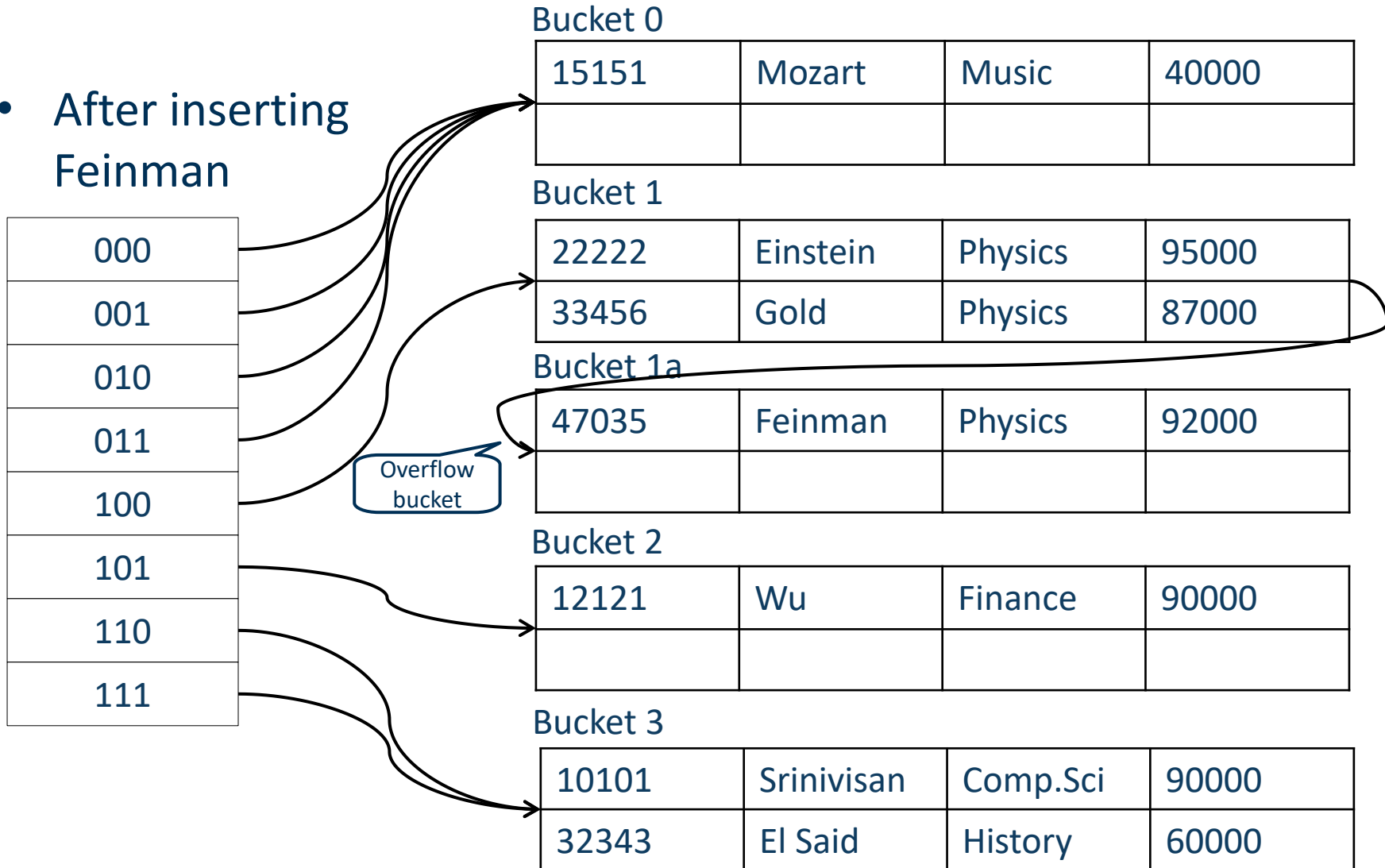

Extendable Hashing

- Benefits
 - Hash performance does not degrade with growth of file
 - Minimal space overhead
- Disadvantages
 - Extra level of indirection to find desired record
 - Bucket address table may itself become very big (larger than memory)
 - Cannot allocate very large contiguous areas on disk either
 - Solution: B⁺-tree structure to locate desired record in bucket address table
 - Changing size of bucket address table is an expensive operation

Comparison of Indexing and Hashing

- Expected type of queries:
 - Hashing is generally better at retrieving records having a specified value of the key
 - If range queries are common, ordered indices are to be preferred
- Cost of periodic re-organization
- Relative frequency of insertions and deletions
- Average vs. worst case access time
- Which index type is supported by the DBMS at hand?

Bitmap Indices

- B+-Trees and Hash Functions are good for attributes with *many different* values
 - e.g., names, matriculation numbers, salaries, ...
- They do not work well for attributes with *few* values
 - e.g., gender (m/f/d), term (spring/autumn), ...
- Thought exercise:
 - construct a B+-Tree / a hash index on one of these attributes

Bitmap Indices

- Special type of index designed for efficient querying on multiple keys
- Records in a relation are assumed to be numbered sequentially from, say, 0
 - Given a number n it must be easy to retrieve record n
- Applicable on attributes that take on a relatively small number of distinct values
 - e.g. gender, country, state, ...
 - e.g. income-level (income broken up into a small number of levels such as 0-9999, 10000-19999, 20000-50000, 50000- infinity)
- A bitmap is simply an array of bits
- CPUs can process them very efficiently (i.e., 32 or 64 bits at once)

Bitmap Indices

- In its simplest form a bitmap index on an attribute has a bitmap for each value of the attribute
 - Bitmap has as many bits as records
 - In a bitmap for value v , the bit for a record is 1 if the record has the value v for the attribute, and is 0 otherwise

ID	Gender	Income Level
76766	m	L1
22222	f	L2
12121	d	L1
15151	f	L4
58583	f	L5

m	1	0	0	0	0
f	0	1	0	1	1
d	0	0	1	0	0

L1	1	0	1	0	0
L2	0	1	0	0	0
L3	0	0	0	0	0
L4	0	0	0	1	0
L5	0	0	0	0	1

Bitmap Indices

- Bitmap indices are useful for queries on multiple attributes
 - not particularly useful for single attribute queries
- Queries are answered using bitmap operations
 - Intersection (and)
 - Union (or)
 - Negation (not)
- Each operation takes two bitmaps of the same size and applies the operation on corresponding bits to get the result bitmap
 - Males with income level L1: $10000 \text{ AND } 10100 = 10000$
 - People with income level L3 to L5: $00000 \text{ OR } 00010 \text{ OR } 00001 = 00011$
 - Females with income above L1: $01011 \text{ AND } (\text{NOT } 10100) = 01011$
- Can then retrieve required tuples
 - Counting number of matching tuples is even faster!

Selected Other Index Types

- Tries (also known as Prefix Trees)

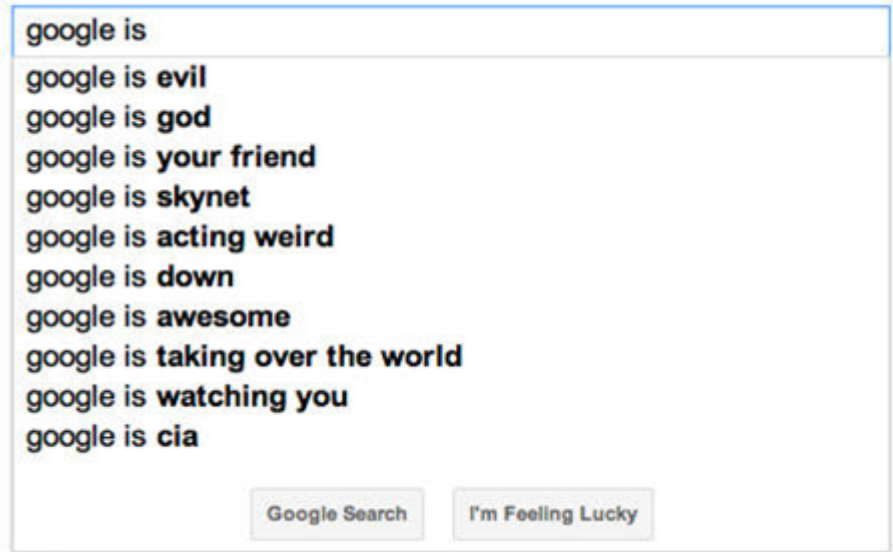
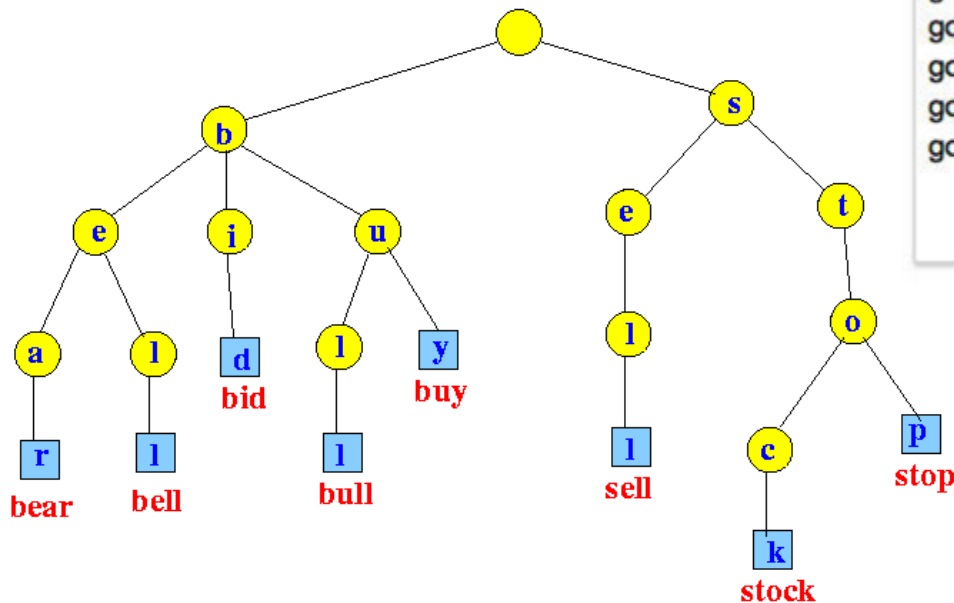

Selected Other Index Types

- R-Trees and kd trees

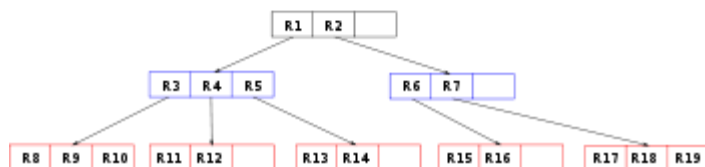
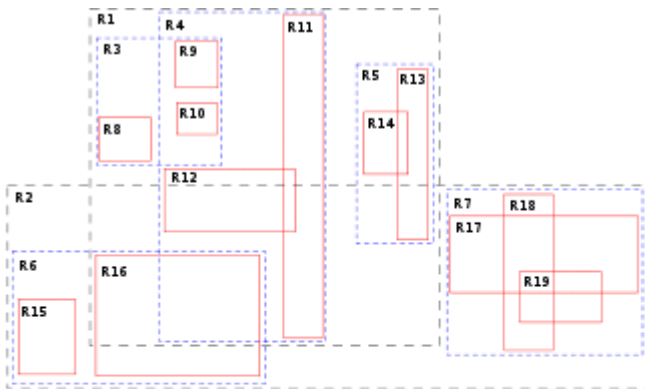

Summary

- Index structures help making queries efficient
 - Practically, speedup by many orders of magnitude
- Trading off storage against computation time
- We've got to know different flavors
 - Table index
 - B⁺-Tree
 - Hash tables
 - Bitmap indices
- Choice of an index structure
 - Desired queries (single/multi attribute? range or value? counting?)
 - Frequency of updates
 - Real time requirements

Questions?

