

Recovery

CS460 Databases for Data Scientists



Flashback to First Lecture

- We already stumbled upon transactions

```
Delete from file: active lecturers  
Add to file: retired lecturers
```

Computer crashes here

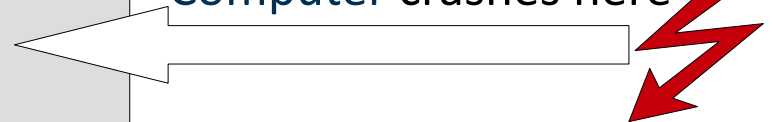

File: **active** lecturers

```
Prof. Smith  
Dr. Stevens  
Prof. Miller
```

File: **retired** lecturers

```
Dr. Hawkins  
Prof. Brown  
Prof. Wilson
```

Recap: ACID Properties

- **Atomicity:** Either all operations of the transaction are properly reflected in the database, or none
- **Consistency:** Execution of a full transaction preserves the consistency of the database
- **Isolation:** Although multiple transactions may execute concurrently, each transaction must be unaware of other concurrently executing transactions
 - Intermediate transaction results must be hidden from other concurrently executed transactions
 - i.e., for every pair of transactions T_i and T_j , it appears to T_i that either T_j finished execution before T_i started, or T_j started execution after T_i finished
- **Durability:** After a transaction completes successfully, the changes it has made to the database persist, even if there are system failures

Outline

- Failure Classification
- Storage Structure
- Recovery and Atomicity
- Log-Based Recovery
- Recovery Algorithm
- Remote Backup Systems

Failure Classification

- **Transaction failure :**
 - **Logical errors:** transaction cannot complete due to some internal error condition
 - **System errors:** the database system must terminate an active transaction due to an error condition (e.g., deadlock)
- **System crash:** a power failure or other hardware or software failure causes the system to crash.
 - **Fail-stop assumption:** non-volatile storage contents are assumed to not be corrupted as result of a system crash
 - Database systems have numerous integrity checks to prevent corruption of disk data
- **Disk failure:** a head crash or similar disk failure destroys all or part of disk storage
 - Destruction is assumed to be detectable: disk drives use checksums to detect failures

Recovery Algorithms

- Consider a transaction that transfers \$ 50 from account A to account B
 - Two updates: subtract 50 from A and add 50 to B
- Transaction requires updates to A and B to be output to the database
 - A failure may occur after one of these modifications have been made
 - but before both of them are made
 - not ensuring that the transaction will commit may leave the database in an inconsistent state
 - not modifying the database may result in lost updates if failure occurs just after transaction commits
- Recovery algorithms have two parts
 - Actions taken *during normal transaction processing* to ensure enough information exists to recover from failures
 - Actions taken *after a failure* to recover the database contents to a state that ensures atomicity, consistency, and durability

Storage Structure

- **Volatile storage:**
 - does not survive system crashes
 - examples: main memory, cache memory
- **Nonvolatile storage:**
 - survives system crashes
 - examples: disk, tape, flash memory,
non-volatile (battery backed up) RAM
 - but may still fail, losing data
- **Stable storage:**
 - a mythical form of storage that survives all failures
 - approximation: maintaining multiple copies
on distinct nonvolatile media

Stable Storage Approximation

- Maintain multiple copies of each block on separate disks
 - copies can be at remote sites to protect against disasters such as fire or flooding
- Failure during data transfer can still result in inconsistent copies:
 - Block transfer can result in
 - Successful completion
 - Partial failure: destination block has incorrect information
 - Total failure: destination block was never updated
- Protecting storage media from failure during data transfer (one solution):
 - Execute output operation as follows (assuming two copies of each block):
 - 1) Write the information onto the first physical block
 - 2) When the first write successfully completes, write the same information onto the second physical block
 - 3) The output is completed only after the second write successfully completes

Stable Storage Approximation

- Protecting storage media from failure during data transfer (cont.):
- Copies of a block may differ due to failure during output operation.
- To recover from failure:
 - First find inconsistent blocks
 - Expensive solution: Compare the two copies of every disk block
 - Better solution: Record in-progress disk writes on non-volatile storage (Non-volatile RAM or special area of disk)
 - Use this information during recovery to find blocks that may be inconsistent, and only compare copies of these
 - Used in hardware RAID systems
- If either copy of an inconsistent block is detected to have an error (bad checksum)
 - overwrite it by the other copy
- If both have no error, but are different
 - overwrite the second block by the first block

Data Access and Buffering

- **Physical blocks** are those blocks residing on the disk
- **System buffer blocks** are the blocks residing temporarily in main memory
- Block movements between disk and main memory are initiated through the following two operations:
 - **input**(B) transfers the physical block B to main memory
 - **output**(B) transfers the buffer block B to the disk, and replaces the appropriate physical block there
- **Simplifying assumption:**
 - each data item fits in, and is stored inside, a single block

Data Access and Buffering

- Each transaction T_i has its private work-area in which local copies of all data items accessed and updated by it are kept
 - T_i 's local copy of a data item X is denoted by x_i
 - B_x denotes block containing X
- Transferring data items between system buffer blocks and its private work-area done by:
 - **read**(X) assigns the value of data item X to the local variable x_i
 - **write**(X) assigns the value of local variable x_i to data item $\{X\}$ in the buffer block
- Transactions
 - Must perform **input**(X) before accessing X for the first time (subsequent reads can be from local copy)
 - The **write**(X) can be executed at any time before the transaction commits
- Note that **output**(B_x) need not immediately follow **write**(X)
 - system can perform the **output** operation when it deems fit

Data Access and Buffering

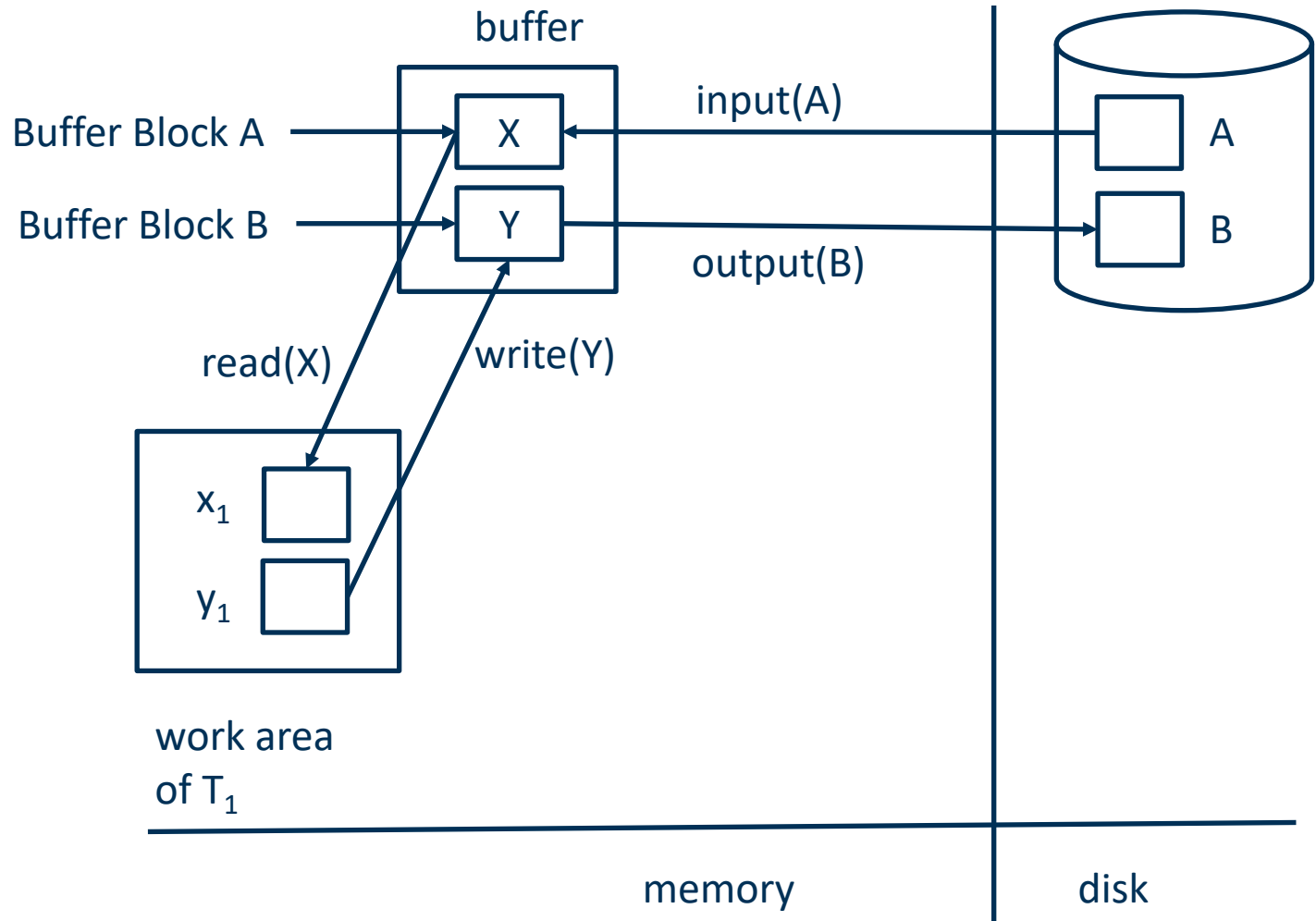

Recovery and Atomicity

- How can we ensure atomicity despite failures?
 - *first* output information describing the modification to stable storage
 - *then* modify the database itself
- This is called a **log-based recovery mechanism**
- For the moment, we assume serial execution for simplicity
 - parallel variants exist

Log-based Recovery

- A **log** is kept on stable storage
 - sequence of **log records**
 - maintains information about update activities on the database
- When transaction T_i starts, it registers itself by writing a record $\langle T_i \text{ start} \rangle$ to the log
- *Before* T_i executes **write**(X), a log record is written $\langle T_i, X, V_1, V_2 \rangle$ where V_1 is the value of X before the write (the **old value**), and V_2 is the value to be written to X (the **new value**)
- When T_i finishes its last statement, the log record $\langle T_i \text{ commit} \rangle$ is written
- Two approaches using logs
 - Immediate database modification
 - Deferred database modification

Database Modification

- The **immediate modification** scheme allows updates of an uncommitted transaction to be made to the buffer, or the disk itself, before the transaction commits
 - Update log record must be written *before* a database item is written
 - we assume that the log record is output immediately to stable storage
 - however, it is possible to postpone log record output to some extent
 - Output of updated blocks to disk storage can take place at any time before or after transaction commit
 - Order in which blocks are output can be different from the order in which they are written
- The **deferred modification** scheme performs updates to buffer/disk only at the time of transaction commit
 - simplifies some aspects of recovery
 - but has overhead of storing local copy
- For the moment, we only consider the immediate modification scheme

Transaction Commit

- A transaction is said to have committed when its commit log record is output to stable storage
 - All previous log records of the transaction must have been output already
- Writes performed by a transaction may still be in the buffer when the transaction commits
 - and may be output later

Immediate Database Modification Example

Log	Write	Output
-----	-------	--------

< T_0 start>

< T_0 , A, 1000, 950>

< T_0 , B, 2000, 2050>

A = 950

B = 2050

< T_0 commit>

< T_1 start>

< T_1 , C, 700, 600>

C = 600

< T_1 commit>

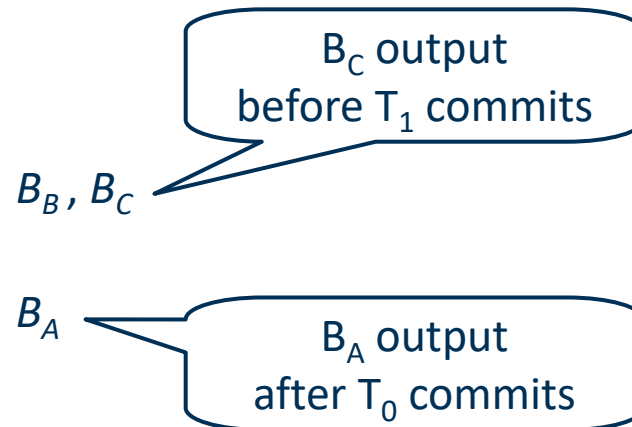

- Note: B_X denotes block containing X

Undo and Redo Operations

- **Undo** of a log record $\langle T_i, X, V_1, V_2 \rangle$ writes the **old** value V_1 to X
- **Redo** of a log record $\langle T_i, X, V_1, V_2 \rangle$ writes the **new** value V_2 to X
- **Undo and Redo of Transactions**
 - **undo**(T_i) restores the value of all data items updated by T_i to their old values, going backwards from the last log record for T_i
 - Each time a data item X is restored to its old value V a special log record (called **redo-only**) $\langle T_i, X, V \rangle$ is written out
 - When undo of a transaction is complete, a log record $\langle T_i, \mathbf{abort} \rangle$ is written out (to indicate that the undo was completed)
 - **redo**(T_i) sets the value of all data items updated by T_i to the new values, going forward from the first log record for T_i
 - No logging is done in this case

Undo and Redo Operations

- **undo** and **redo** operations are used in several different circumstances:
- **undo** is used
 - for *transaction rollback* during normal operation (in case a transaction cannot complete its execution due to some logical error)
- **undo** and **redo** operations are used during recovery from failure
 - We need to deal with the case where during recovery from failure, another failure occurs prior to the system having fully recovered

Transaction Rollback

- Let T_i be the transaction to be rolled back
- Scan log backwards from the end,
and for each log record of T_i of the form $\langle T_i, X_j, V_1, V_2 \rangle$
 - Perform the undo by writing V_1 to X_j
 - Write a log record $\langle T_i, X_j, V_1 \rangle$
 - such log records are called **compensation log records**
- Once the record $\langle T_i, \mathbf{start} \rangle$ is found stop the scan and write the log record $\langle T_i, \mathbf{abort} \rangle$

Recovering from Failure

- When recovering after failure:
 - Transaction T_i needs to be undone if the log
 - contains the record $\langle T_i \text{ start} \rangle$,
 - but does not contain either the record $\langle T_i \text{ commit} \rangle$ or $\langle T_i \text{ abort} \rangle$
 - Transaction T_i needs to be redone if the log
 - contains the records $\langle T_i \text{ start} \rangle$
 - and contains the record $\langle T_i \text{ commit} \rangle$ or $\langle T_i \text{ abort} \rangle$
- Why redo transaction T_i if the case of $\langle T_i \text{ abort} \rangle$?
 - for $\langle T_i \text{ abort} \rangle$, there are also redo-only records for the undo operation
 - the end result will be to undo T_i 's modifications in this case
 - redo *all* original actions including the steps that restored the old value
 - known as *repeating history*
 - simplifies the recovery algorithm, enables faster overall recovery time

Examples for Immediate Recovery

- Below we show the log as it appears at points in time:

$\langle T_0 \text{ start} \rangle$	$\langle T_0 \text{ start} \rangle$	$\langle T_0 \text{ start} \rangle$
$\langle T_0, A, 1000, 950 \rangle$	$\langle T_0, A, 1000, 950 \rangle$	$\langle T_0, A, 1000, 950 \rangle$
$\langle T_0, B, 2000, 2050 \rangle$	$\langle T_0, B, 2000, 2050 \rangle$	$\langle T_0, B, 2000, 2050 \rangle$
	$\langle T_0 \text{ commit} \rangle$	$\langle T_0 \text{ commit} \rangle$
	$\langle T_1 \text{ start} \rangle$	$\langle T_1 \text{ start} \rangle$
	$\langle T_1, C, 700, 600 \rangle$	$\langle T_1, C, 700, 600 \rangle$
		$\langle T_1 \text{ commit} \rangle$
(a)	(b)	(c)

- Recovery actions in each case above are:
 - undo (T0): B is restored to 2000 and A to 1000, and log records $\langle T_0, B, 2000 \rangle$, $\langle T_0, A, 1000 \rangle$, $\langle T_0, \text{abort} \rangle$ are written out
 - redo (T0) and undo (T1): A and B are set to 950 and 2050, and C is restored to 700.
Log records $\langle T_1, C, 700 \rangle$, $\langle T_1, \text{abort} \rangle$ are written out
 - redo (T0) and redo (T1): A and B are set to 950 and 2050 respectively. Then C is set to 600

Checkpoints

- Redoing/undoing all transactions recorded in the log can be very slow
 - Processing the entire log is time-consuming if the system has run for a long time
 - We might unnecessarily redo transactions which have already output their updates to the database
- Streamline recovery procedure by periodically performing checkpointing
 - All updates are stopped while doing checkpointing
 - Output all log records currently residing in main memory onto stable storage
 - Output all modified buffer blocks to the disk
 - Write a log record <checkpoint L> onto stable storage where L is a list of all transactions active at the time of checkpoint

Checkpoints

- During recovery we need to consider only the most recent transaction T_i that started before the checkpoint, and transactions that started after T_i
 - Scan backwards from end of log to find the most recent <checkpoint L> record
 - Only transactions that are in L or started after the checkpoint need to be redone or undone
- Transactions that committed or aborted before the checkpoint already have all their updates output to stable storage
 - Some earlier part of the log may be needed for undo operations
 - Continue scanning backwards till a record < T_i start> is found for every transaction T_i in L
 - Parts of log prior to earliest < T_i start> record above are not needed for recovery, and can be erased whenever desired

Checkpoints

- T_1 can be ignored
 - updates have already been output to disk due to checkpoint
- T_2 and T_3 are redone
- T_4 is undone

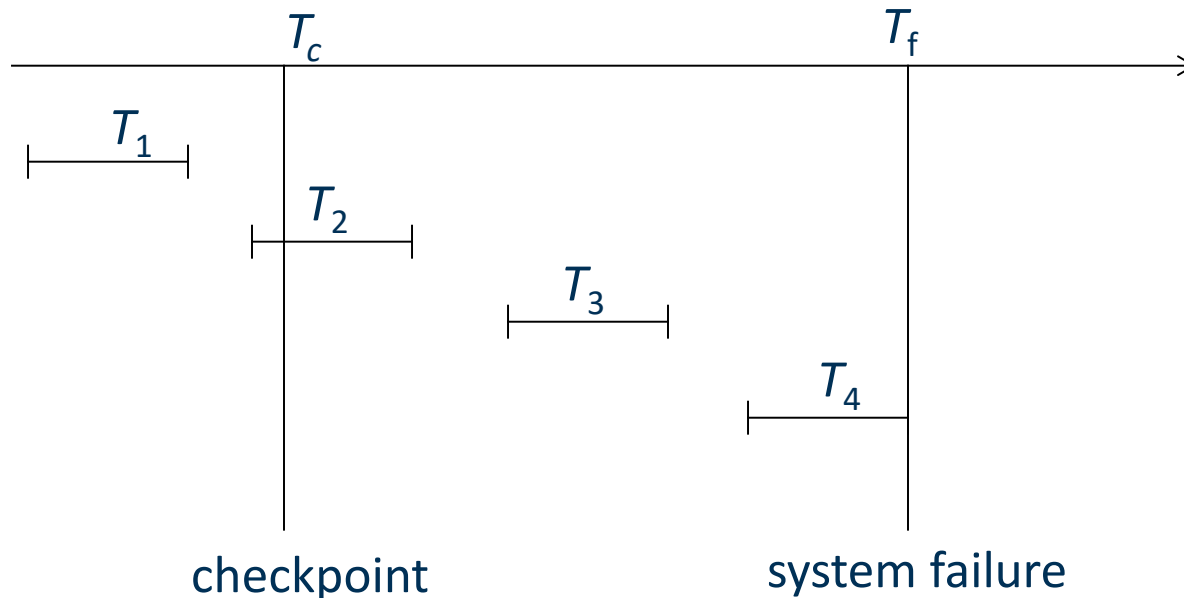

The Recovery Algorithm

- **Logging** (during normal operation):
 - $\langle T_i \text{ start} \rangle$ at transaction start
 - $\langle T_i, X_j, V_1, V_2 \rangle$ for each update, and
 - $\langle T_i \text{ commit} \rangle$ at transaction end
- **Transaction rollback (during normal operation)**
 - Let T_i be the transaction to be rolled back
 - Scan log backwards from the end,
and for each log record of T_i of the form $\langle T_i, X_j, V_1, V_2 \rangle$
 - write a log record $\langle T_i, X_j, V_1 \rangle$
 - perform the undo by writing V_1 to X_j
 - such log records are called **compensation log records**
 - Once the record $\langle T_i \text{ start} \rangle$ is found
 - stop the scan and write the log record $\langle T_i \text{ abort} \rangle$

The Recovery Algorithm

- **Recovery from failure:** Two phases
 - **Redo phase:** replay updates of **all** transactions, whether they committed, aborted, or are incomplete
 - **Undo phase:** undo all incomplete transactions

The Recovery Algorithm

- **Redo phase:**
 - Find last **<checkpoint L>** record, and set undo-list to L .
 - Scan forward from above **<checkpoint L>** record
 - Whenever a record $\langle T_i, X_j, V_1, V_2 \rangle$ is found,
 - redo it by writing V_2 to X_j
 - Whenever a log record $\langle T_i, \text{start} \rangle$ is found
 - add T_i to undo-list
 - Whenever a log record $\langle T_i, \text{commit} \rangle$ or $\langle T_i, \text{abort} \rangle$ is found
 - remove T_i from undo-list

The Recovery Algorithm

- **Undo phase:**
 - Scan log backwards from end
 - When a log record $\langle T_i, X_j, V_1, V_2 \rangle$ is found where T_i is in undo-list
 - perform same actions as for transaction rollback:
 - perform undo by writing V_1 to X_j .
 - write a log record $\langle T_i, X_j, V_1 \rangle$
 - When a log record $\langle T_i \text{ start} \rangle$ is found where T_i is in undo-list
 - Write a log record $\langle T_i \text{ abort} \rangle$
 - Remove T_i from undo-list
 - Stop when undo-list is empty
 - i.e., $\langle T_i \text{ start} \rangle$ has been found for every transaction in undo-list
- After undo phase completes, normal transaction processing can commence

Recovery Example

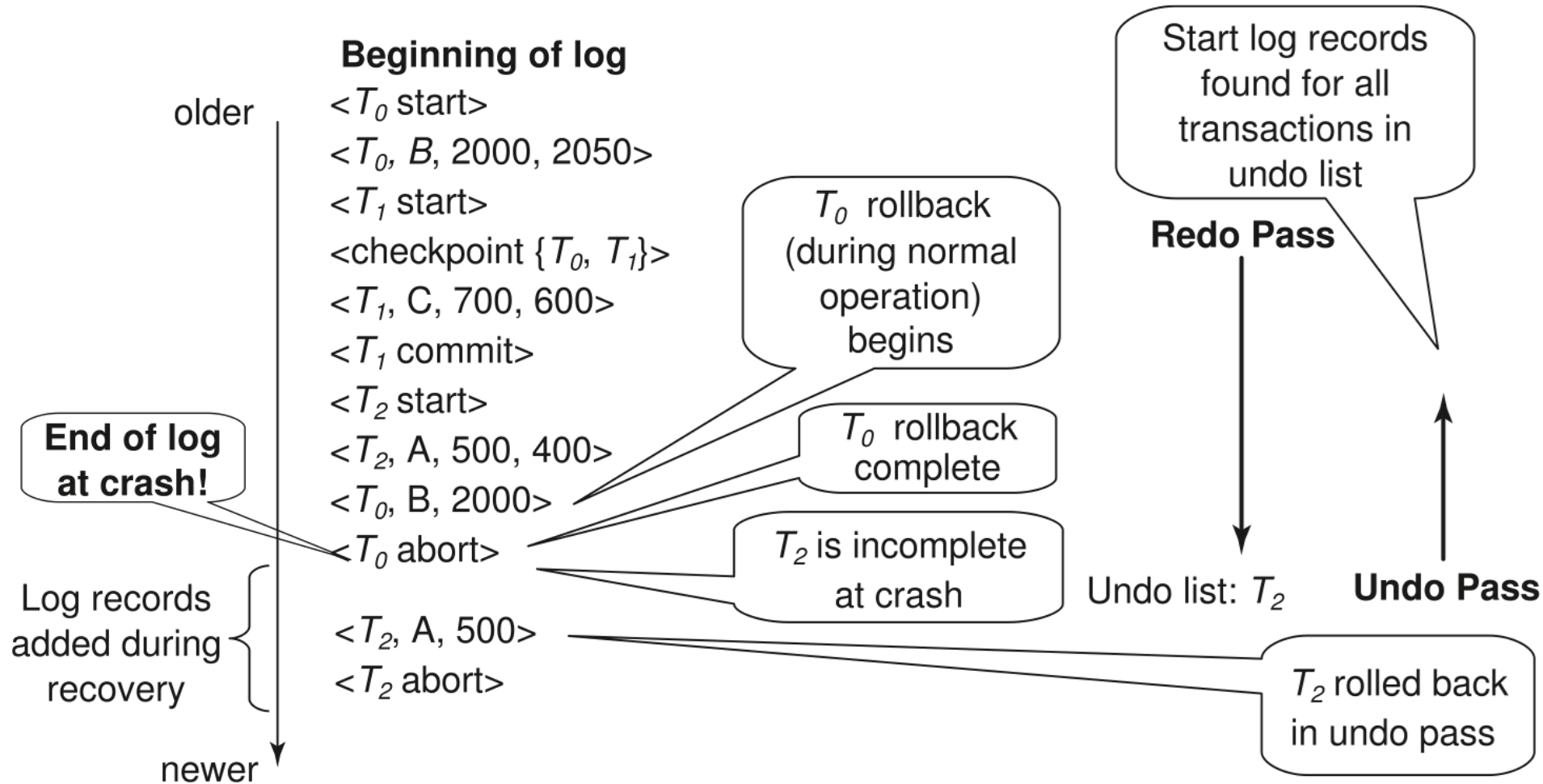

Log Record Buffering

- **Log record buffering:**
 - log records are buffered in main memory
 - instead of being output directly to stable storage
- Log records are output to stable storage
 - when a block of log records in the buffer is full
 - or a **log force** operation is executed
- Log force is performed to commit a transaction
 - by forcing all its log records (including the commit record) to stable storage
 - Several log records can thus be output using a single output operation, reducing the I/O cost

Log Record Buffering & Write-Ahead Logging

- The rules below must be followed if log records are buffered:
 - Log records are output to stable storage in the order of creation
 - Transaction T_i enters the commit state only when the log record $\langle T_i \text{ commit} \rangle$ has been output to stable storage
 - Before a block of data in main memory is output to the database, all log records pertaining to data in that block must have been output to stable storage
 - This rule is called the **write-ahead logging** or **WAL** rule

Fuzzy Checkpointing

- To avoid long interruption of normal processing during checkpointing, allow updates to happen during checkpointing
- Fuzzy checkpointing is done as follows:
 - Temporarily stop all updates by transactions
 - Write a <checkpoint L> log record and force log to stable storage
 - Note list M of modified buffer blocks
 - Now permit transactions to proceed with their actions
 - Output to disk all modified buffer blocks in list M
 - blocks should not be updated while being output
 - Follow WAL: all log records pertaining to a block must be output before the block is output
 - Store a pointer to the checkpoint record in a fixed position last_checkpoint on disk

Fuzzy Checkpointing

- When recovering using a fuzzy checkpoint, start scan from the **checkpoint** record pointed to by **last_checkpoint**
 - Log records before **last_checkpoint** have their updates reflected in database on disk, and need not be redone
 - Incomplete checkpoints, where system had crashed while performing checkpoint, are handled safely

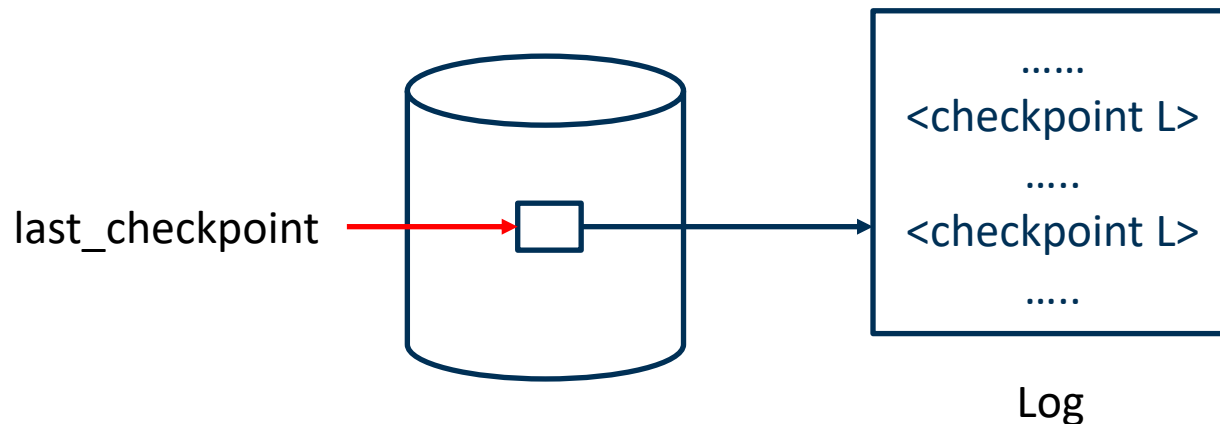

Failure with Loss of Non-volatile Storage

- So far we assumed no loss of non-volatile storage
- Technique similar to checkpointing used to deal with loss of non-volatile storage
 - Periodically **dump** the entire content of the database to stable storage
 - No transaction may be active during the dump procedure
 - a procedure similar to checkpointing must take place
- Output all log records currently in main memory onto stable storage
 - Output all buffer blocks onto the disk
 - Copy the contents of the database to stable storage
 - Output a record **<dump>** to log on stable storage

Recovery from Failure of Non-volatile Storage

- To recover from disk failure
 - restore database from most recent dump
 - consult the log and redo all transactions that committed after the dump
- Can be extended to allow transactions to be active during dump; known as fuzzy dump or online dump
 - Similar to fuzzy checkpointing

Remote Backup Systems

- Risk minimization:
 - allowing transaction processing to continue even if the primary site is destroyed

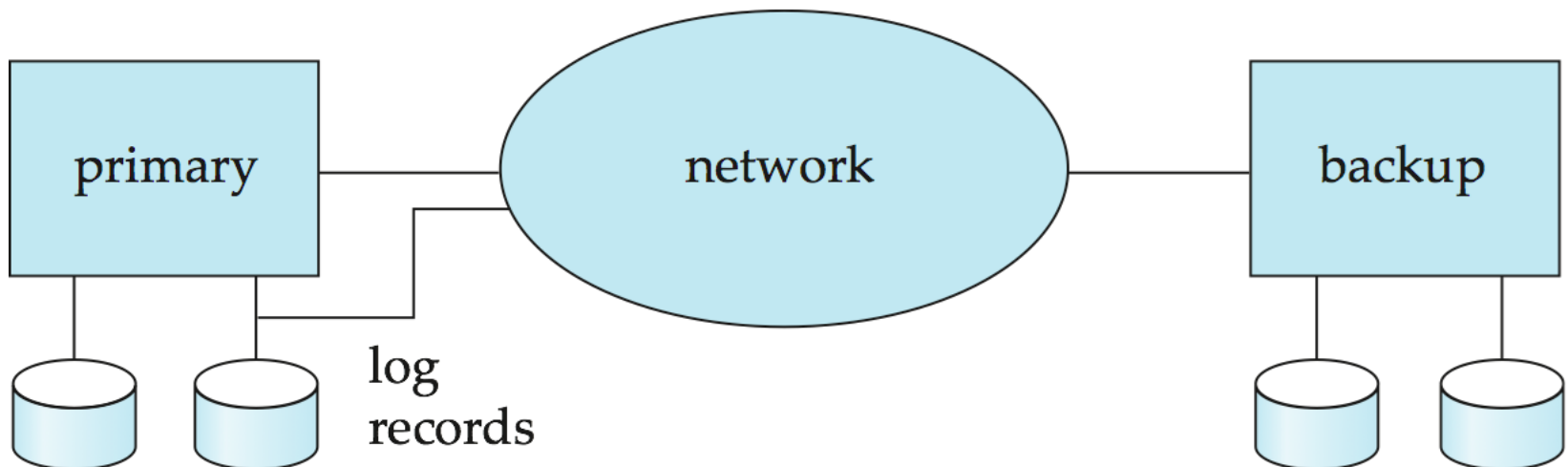

Remote Backup Systems

- **Detection of failure:**
 - Backup site must detect when primary site has failed
 - to distinguish primary site failure from link failure: maintain *several* communication links in between
 - Heart-beat messages
- **Transfer of control:**
 - To take over control backup site first performs recovery using its copy of the database and all the log records it has received from the primary
 - i.e., completed transactions are redone and incomplete transactions are rolled back
 - When the backup site takes over processing it becomes the new primary
 - To transfer control back to old primary when it recovers
 - old primary must receive redo logs from the old backup and apply all updates locally

Remote Backup Systems

- **Time to recover** – reduce delay in takeover
 - backup site periodically processes the redo log records
 - i.e., performs recovery from previous database state
 - performs a checkpoint, and can then delete earlier parts of the log
- **Hot-Spare configuration permits very fast takeover:**
 - Backup continually processes redo log records as they arrive
 - applying the updates locally
 - When failure of the primary is detected
 - the backup rolls back incomplete transactions
 - and is ready to process new transactions
- **Alternative to remote backup:**
distributed database with replicated data
 - Remote backup is faster and cheaper, but less tolerant to failure

Remote Backup Systems

- Ensure durability of updates by delaying transaction commit
 - until update is logged at backup
 - avoid this delay by permitting lower degrees of durability
- One-safe: commit as soon as transaction's commit log record is written at primary
 - Problem: updates may not arrive at backup before it takes over
- Two-very-safe: commit when transaction's commit log record is written at primary and backup
 - Reduces availability since transactions cannot commit if either site fails
- Two-safe: proceed as in two-very-safe if both primary and backup are active
 - If only the primary is active, the transaction commits as soon as its commit log record is written at the primary
 - Better availability than two-very-safe
 - avoids problem of lost transactions in one-safe

Concurrency Control and Recovery

- All transactions share a single disk buffer and a single log
 - A buffer block can have data items updated by one or more transactions
- Log records of different transactions may be interspersed in the log
- We assume that *if a transaction T_i has modified an item, no other transaction can modify the same item until T_i has committed or aborted*
 - i.e. the updates of uncommitted transactions should not be visible to other transactions
 - otherwise, how do we perform undo if T_1 updates A, then T_2 updates A and commits, and finally T_1 has to abort?
 - can be ensured by obtaining exclusive locks on updated items and holding the locks till end of transaction (strict two-phase locking)

Data Access and Buffering (revisited)

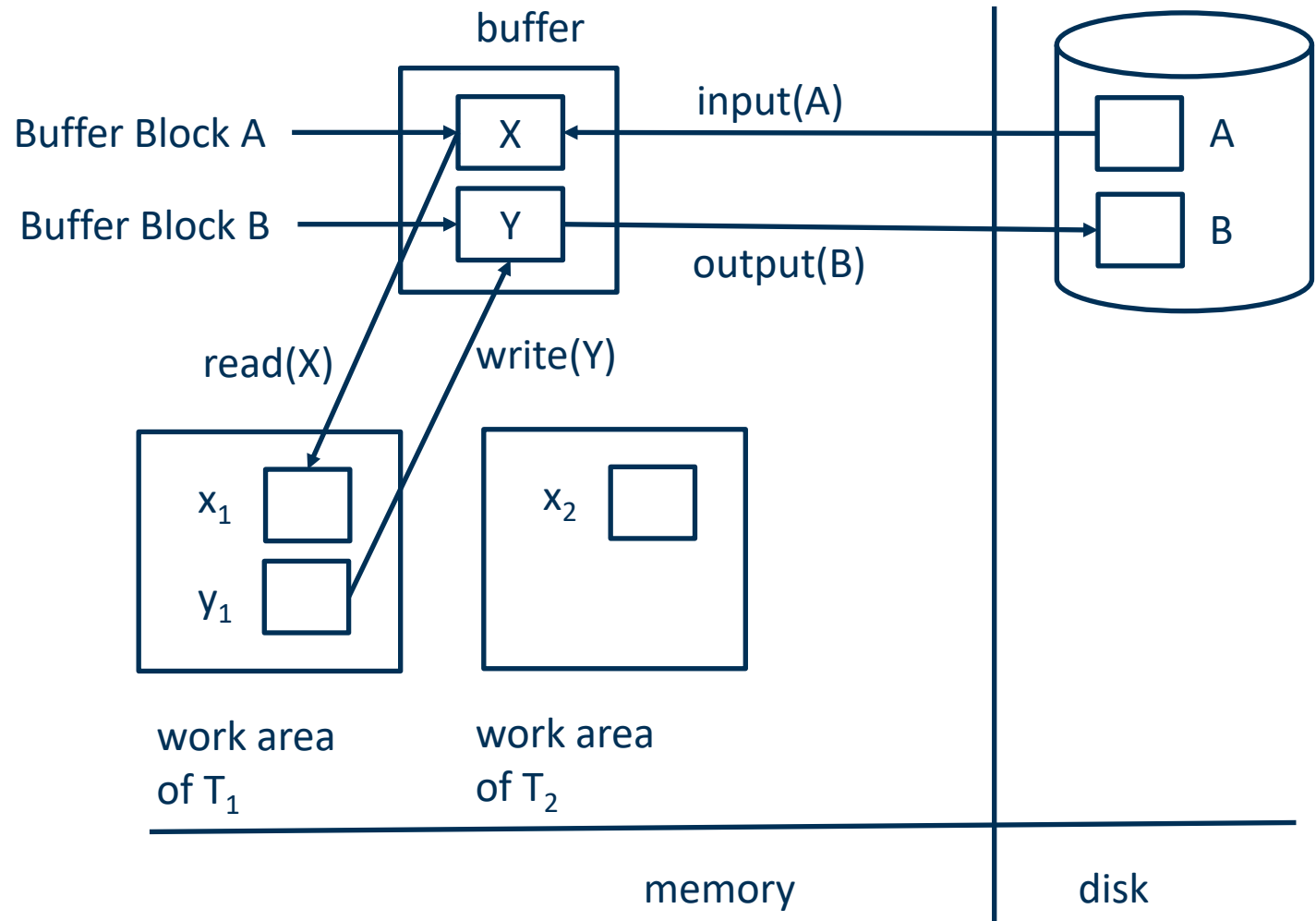

Summary

- Recovery ensures consistency of the database
 - handles rollbacks
 - takes care of setting the database back to operation after failures
- Mechanisms
 - Logs: write ahead (write log first, then write data)
 - Checkpoints
- Trade off between normal and recovery performance
 - e.g., by using fuzzy checkpoints
- Remote backup
 - distribution of risk
- Recovery and Concurrency

Questions?

